

Wall Mount Bracket

For use with DH-PFH610V Series Camera Housings



- Aluminum Construction
- Supports DH-PFH610V Series Camera Housings
- 5.0 kg (11.02 lb) Maximum Load Bearing Capacity

Technical Specifications

Material	Aluminum
Color	White
Dimensions (W x H x D)	92.0 mm x 121.30 mm x 284.50 mm (3.62 in. x 4.78 in. x 11.20 in.)
Weight	0.65 kg (1.43 lb)
Load Bearing Capacity	5.0 kg (11.02 lb)
Operating Temperature	-40° C to 60° C (-40° F to 140° F)
Humidity	0% to 90% RH
Compatible Models	DH-PFH610V DH-PFH610V-IR

Ordering Information

Type	Part Number	Description
Wall Mount	DH-PFB605W	Wall Mount Bracket for DH-PFH610V Series Camera Housings
Package Contents	2 x M6 x 14 Screws 2 x 1/4-20 Screws 1 x S5.0 Wrench	

Dimensions (mm/in.)

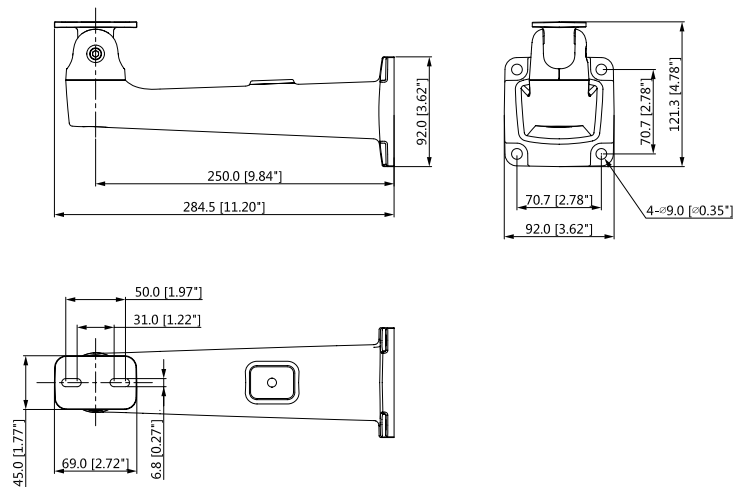

Application

