

DH-PFA5300R

Water-proof Junction Box



- Built of aluminum alloy.
- Suitable for a variety of cameras and is elegant.
- IP66 junction box.



Scene

Ideal for mounting cameras, it works in temperatures ranging from -40°C to $+60^{\circ}\text{C}$ (-40°F to $+140^{\circ}\text{F}$) and in environments with relative humidity of less than 90%.

Technical Specification

Structure

Product Material	Aluminum alloy
Product Dimensions	$\Phi 123.4\text{ mm} \times 44.9\text{ mm}$ ($\Phi 4.86'' \times 1.77''$)
Appearance Color	White
Net Weight	0.39 kg (0.86 lb)
Gross Weight	0.51 kg (1.12 lb)
Load Bearing	3.0 kg (6.61 lb)
Installation	Junction Mount
Screw Thread Type	G3/4
Applicable Model	Please see "Camera Accessories Selection"
Packaging Dimensions	$187.0\text{ mm} \times 164.0\text{ mm} \times 72.0\text{ mm}$ ($7.36'' \times 6.46'' \times 2.83''$) (L x W x H)
Transport Package Dimensions	$578.0\text{ mm} \times 383.0\text{ mm} \times 349.0\text{ mm}$ ($22.76'' \times 15.08'' \times 13.74''$) (L x W x H)
Packaging Method	30 pcs in each carton
Environment	
Protection	IP66
Operating Temperature	-40°C to $+60^{\circ}\text{C}$ (-40°F to $+140^{\circ}\text{F}$)
Operating Humidity	< 90% (RH)
Storage Temperature	-40°C to $+60^{\circ}\text{C}$ (-40°F to $+140^{\circ}\text{F}$)
Storage Humidity	10%–90% (RH)

Ordering Information

Type	Model	Description
Camera Mount	DH-PFA5300R	Water-proof Junction Box
	PFA5300R	Water-proof Junction Box

Installation

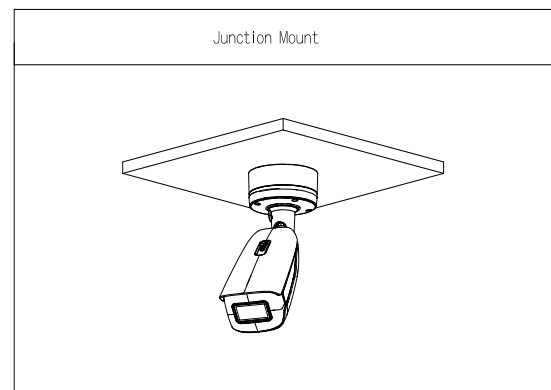

Dimensions (mm[inch])

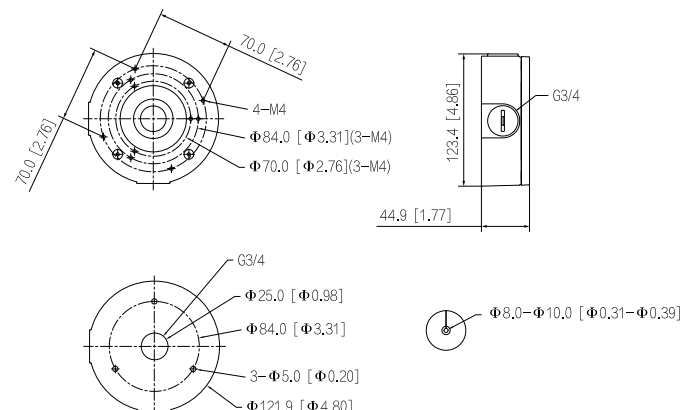

Package Information

- Water-proof Junction Box × 1
- M4 × 10 screws × 4
- ST4 × 25 screws × 3
- Plastic expansion bolt × 3
- S3.0 wrench × 1
- Water Joint × 1
- Mounting Sticker × 1