

IRIS PS72

Back-up power supply unit for
IRIS addressable fire alarm panel



1293

DoP No: 059

Tested by EVPU

Teletek Electronics JSC

Address: 2 Iliyansko shose Str,
1220 Sofia, Bulgaria

EN 54-4:1997

EN 54-4:1997/AC:1999

EN 54-4:1997/A1:2001

EN 54-4:1997/A2:2006

ATTENTION:

Read carefully this installation Instructions
before installing the device! This manual is
subject to change without notice!

Installation

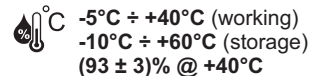

18020959; RevB; 04/2024

IMPORTANT NOTES

- **Warning!** An appropriate disconnect device shall be provided as part of the building.
- **Switch OFF** the main power supply and the battery of the IRIS panel before installing the IRIS PS72 power supply unit!
- **Use only the connection cables supplied with the equipment:** red and black wires for connection to JP4 terminals; white and grey wires for connection to FLT terminals! Do not shorten or extending these cables!
- **Make all the wiring observing the polarity of the connections following the presented connection diagrams. If after powering on the IRIS PS72, the LED "WRONG CONNECTION" is lighting on, switch off the power supply immediately and check the connection between the power supply unit of IRIS panel and terminals JP4 of IRIS PS72!**
- **If the LED "Hi Resist" for Battery 1 or 2 is blinking it is strongly recommended to change the batteries immediately!**
- **The cover is mounted to the box bottom with hinges fixed with dismountable rivets. The angle of opening of the front cover must not be greater than 110°!**

TECHNICAL SPECIFICATIONS

Main power supply 230V~ +10%/ -15%, 0.6A, 4A fuse
 Frequency 50-60Hz
 DC Output:
 - Voltage 9.9-14.2V===
 - Max. Current 7A@1 battery, 14A@2 batteries
 Int. resistance of the battery Ri . . . < 0.3Ohm
 Max. battery capacity 2x12V/18Ah
 Charger outputs 13.65V=== ±1%@20°C, max. 2A
 Color of the box grey
 Dimensions 430x330x117mm
 Max. dimensions of 1 battery . . . 167x181x76mm

Installation

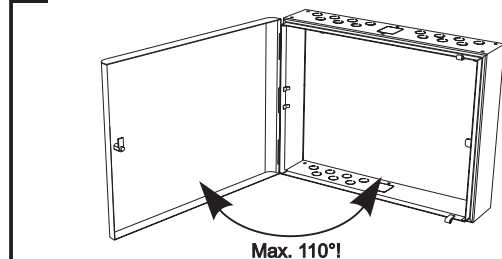

INSTALLATION INSTRUCTIONS

General Description

IRIS PS72 is a power supply unit designed for back-up power supply of IRIS addressable fire alarm panel. The power supply is placed into a metal box suitable for building of a modular structure with the addressable panel and a second power supply unit. The access to the main board and the cable connections is secured with a key.

The status of IRIS PS72 is displayed via a LED indication on the main PCB. The status of the power supply unit can be continuously monitored with enabling the option "External PSU Check" from the IRIS panel menus. When the option is enabled the panel will display a fault message "External Power Supply Fault, Periphery Device 1-PSU" in case of any trouble with the power supply. The respective trouble of the power supply is visualized with a blinking LED on the PCB.

At normal operation mode only "OK" green LED is blinking and all other LEDs are off. In case of main power supply (230V~) loss the "FLT" yellow LED starts blinking and "OK" green LED is off. In case of trouble with a Battery 1 and/or 2, the yellow LEDs at sections Batt1 and/or Batt2 are blinking. A detail description of all LED indicators is performed at Item 2: IRIS PS72 Main Board - see on page 2.

Mounting

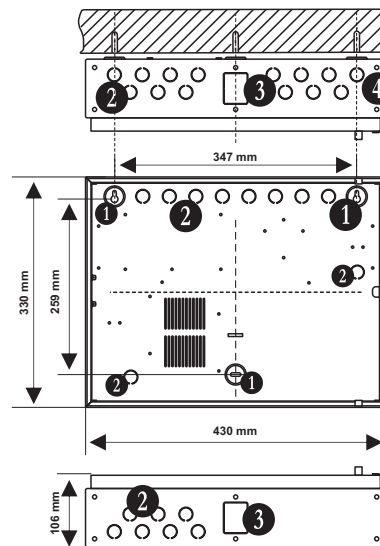

1 - Mounting holes

2 - Openings for running cables - on the box bottom, on the up and down side*

3 - Opening for running cables when a few panels are fixed in a modular structure*

4 - Ø 5mm openings (4 on upside and 4 on downside on the box bottom) for fixing the panel to other boxes from the same type

* Protected with a metal cap element

1 Elements

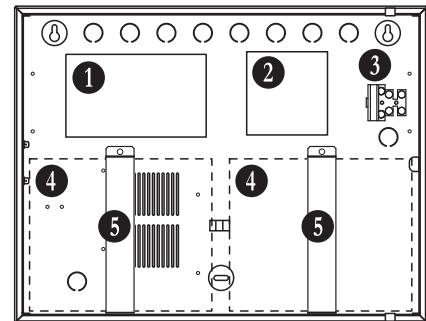

- 1 - Main board
- 2 - Power supply unit
- 3 - Main power supply (terminal 230V~)
- 4 - Place for a battery
- 5 - Battery bracket*

* Note: The batteries must be firmly tighten with the brackets to the box bottom!

3 Connection Diagrams

NOTE: At FLT terminals, the arrows pointing inward the IRIS PS72 main board are marking the terminals for input signals to the board, and the arrows pointing outward are marking the terminals for output signals from the board.

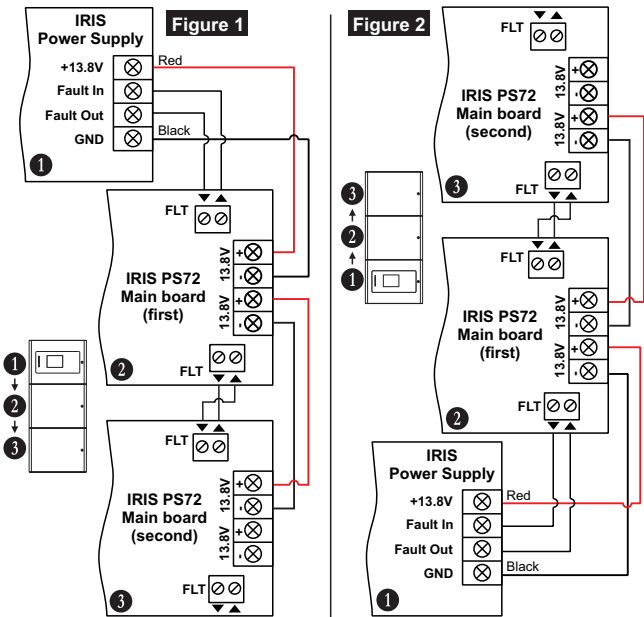

2 IRIS PS72 Main Board

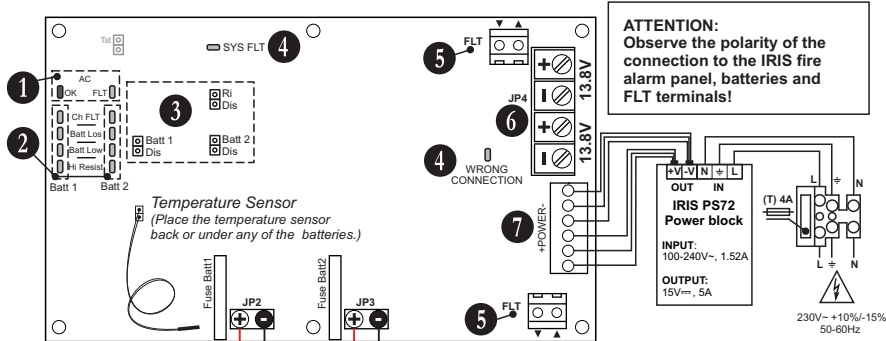

ATTENTION: Observe the polarity of the connection to the IRIS fire alarm panel, batteries and FLT terminals!

IMPORTANT! If after powering up both the IRIS panel and IRIS PS72 backup power supply, the LED "WRONG CONNECTION" is lighting on you must TURN OFF the power supply of both devices immediately and check the polarity of the connection!

- 1 - AC Indication for main power supply presence (230V~):
 - "OK" LED (green) - Blinks at presence of main power supply.
 - "FLT" LED (yellow) - Blinks at loss of main power supply.
- 2 - Battery Fault Indication. The indication is separated into two sections - Batt1 (Battery 1 connected to JP2 leads) and Batt2 (Battery 2 connected to JP3 leads). The respective indicator starts blinking in case of following troubles:
 - "Ch FLT" LED (yellow) - battery charging fault.
 - "Batt Los" LED (yellow) - missing or deeply discharged battery (voltage lower than 10V ±10%).
 - "Batt Low" LED (yellow) - discharged battery (voltage range 10V-11V ±10%).
 - "Hi Resist" LED (yellow) - high battery resistance detected. **Attention: The high battery resistance indication must be enabled - no jumper set on "Ri Dis" terminal.**
- 3 - Jumpers for disabling the operation:
 - "Ri Dis" - Set a jumper to disable the indication for high battery resistance.

Attention: The disabling of High Battery Resistance indication is not in conformity with EN54 standard!

 - "Batt 1 Dis" - Set a jumper to disable the operation of the battery connected to JP2 terminal.
 - "Batt 2 Dis" - Set a jumper to disable the operation of the battery connected to JP3 terminal.
- 4 - System Fault Indication.
 - "SYS FLT" LED (yellow) - lights on permanently in case of processor failure.
 - "Wrong Connection" LED (yellow) - lights on permanently in case of reversed polarity of the connection between the IRIS fire alarm panel power supply and JP4 terminal.
- 5 - FLT Terminals. Use the white and the grey wires from the spare parts kit to connect the FAULT IN and FAULT OUT terminals of IRIS power supply to FLT terminal of IRIS PS72 as observing the polarity. The FAULT OUT output will turn on when a problem with main power supply of the IRIS panel occurs. Connect the second FLT terminal of the first IRIS PS72 to the FLT terminal of the second IRIS PS72 as observing the polarity, and so on. **Attention: The FLT terminals are short-circuited, so the wiring depends on the direction of the connection and the position of the IRIS panel in the modular structure - see the connection diagrams.**
- 6 - JP4 Terminal. Power supply terminals to IRIS fire alarm panel. Use the red and the black wires from the spare parts kit to perform the connection as strictly observing the polarity - see the connection diagram.
- 7 - POWER Terminal factory connected to the main power unit of IRIS PS72.

Note: The "Tst" terminal is not used.