

DH-HAC-HDW1100G-M

1MP Mobile HDCVI IR Eyeball Camera

HDCVI



- Max 30fps@720P
- HDCVI output (Aviation connector)
- 3.6mm fixed lens (2.8mm optional)
- Max. IR length 20m, Smart IR
- IP67, DC12V
- Shock-proof



System Overview

Experience full HD 1080P/ HD 720P mobile video surveillance solution with the simplicity of analog infrastructure. The mobile camera is designed with shock-proof property and compact case, which makes it easy to apply and harmonious with the surroundings. It offers high quality image as well as multi-language OSD. Plus, taking advantage of the HDCVI system, the real-time capability is well guaranteed.

Functions

Elaborate Design

For better adapting the applications for vehicles, the mobile camera is designed with micro-sized compact case, which minimizes the interference against on-going activities. Taking aesthetics requirements into consideration, the body and front face of the camera is all-black.

Shock-proof

Vibration is inevitable in mobile applications. In order to avoid image or connection failure, the hardware structure of the mobile camera is shock-proof with the certification of EN50155. Plus, the mobile camera adopts M12 aviation connector for stable connection with MCVR.

Simplicity

HDCVI technology inherits the born feature of simplicity from traditional analog surveillance system, making itself a best choice for investment protection. The plug and play approach enables full HD video surveillance without the hassle of configuring a network. HDCVI system can seamlessly upgrade the traditional analog system without replacing existing cabling.

4 Signals over 1 Coaxial Cable

HDCVI Mobile Camera supports 4 signals to be transmitted over 1 cable simultaneously, i.e. video, audio*, data and power. Dual-way data transmission allows the HDCVI camera to interact with the HCVR, such as sending control signal or triggering alarm.

* Audio input is available for some models of HDCVI cameras.

Smart IR

The camera is designed with array LED IR illumination for best lowlight performance. Smart IR is a technology to ensure brightness uniformity in B/W image under low illumination. Dahua's unique Smart IR adjusts to the intensity of camera's infrared LEDs to compensate for the distance of an object, and prevents IR LEDs from overexposing images as the object come closer to the camera.

Protection

The camera's outstanding reliability is unsurpassed due to its rugged design. The camera is protected against water and dust with IP67 ranking, making it suitable for indoor or outdoor environments. With working temperature range of -40 °C to +80 °C (-40 °F to +176 °F), the camera is designed for extreme temperature environments. Supporting $\pm 25\%$ input voltage tolerance, this camera suits even the most unstable power supply conditions. Its 4KV lightning rating provides protection against the camera and its structure from the effects of lightning.

Technical Specification

Camera

Image Sensor	1/3" CMOS
Effective Pixels	1280(H)×720(V), 1MP
Scanning System	Progressive
Electronic Shutter Speed	PAL: 1/25~1/100000s NTSC: 1/30~1/100000s
Minimum Illumination	0.05Lux/F2.0, 0Lux IR on
S/N Ratio	More than 65dB
IR Distance	Up to 20m (66feet)
IR On/Off Control	Auto / Manual
IR LEDs	1

Lens

Lens Type	Fixed lens / Fixed iris
Mount Type	Board-in
Focal Length	3.6mm (2.8mm Optional)
Max Aperture	F2.0
Angle of View	H: 72.3° (91.6°)
Focus Control	N/A
Close Focus Distance	500mm (400mm) 19.69" (15.75")

Pan / Tilt / Rotation

Pan/Tilt/Rotation	Pan: 0° ~ 360° Tilt: 0° ~ 80° Rotation: 0° ~ 360°
-------------------	---

Video

Resolution	720P (1280×720)
Frame Rate	25/30fps@720P
Video Output	1-channel BNC HDCVI high definition video output (Aviation connector)
Day/Night	Auto (ICR) / Manual
OSD Menu	Multi-language
BLC Mode	BLC / HLC / DWDR
WDR	DWDR
Gain Control	AGC
Noise Reduction	2D
White Balance	Auto / Manual
Smart IR	Auto / Manual

Certifications

Certifications	CE (EN55032, EN55024, EN50130-4) FCC (CFR 47 FCC Part 15 subpartB, ANSI C63.4-2014) UL (UL60950-1+CAN/CSA C22.2 No.60950-1) EN50155 (EN50121-3-2, IEC61373)
----------------	--

Interface

Audio Interface	Built-in Mic
-----------------	--------------

Electrical

Power Supply	12V DC ±25%
Power Consumption	Max 2.3W (12V DC, IR on)

Environmental

Operating Conditions	-40°C ~ +80°C (-40°F ~ +176°F) / Less than 90% RH * Start up should be done at above -40°C (-40°F)
Storage Conditions	-40°C ~ +80°C (-40°F ~ +176°F) / Less than 90% RH
Ingress Protection & Vandal Resistance	IP67

Construction

Casing	Aluminium
Dimensions	Φ62mm×62mm (Φ2.44"×2.44")
Net Weight	0.16kg (0.35lb)
Gross Weight	0.23kg (0.51lb)

Ordering Information

Type	Part Number	Description
1MP Camera	DH-HAC-HDW1100GP-M (2.8mm)	1MP Mobile HDCVI IR Eyeball Camera, PAL
	DH-HAC-HDW1100GP-M (3.6mm)	
	DH-HAC-HDW1100GN-M (2.8mm)	1MP Mobile HDCVI IR Eyeball Camera, NTSC
	DH-HAC-HDW1100GN-M (3.6mm)	

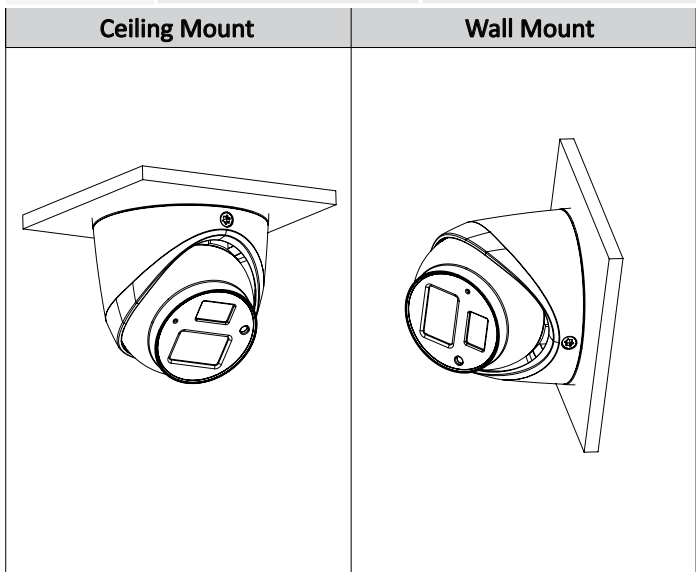

Dimensions (mm/inch)

