

DH-HAP320-V

Hi-fidelity Pickup



Features

- Use metal shell, surface is through plating processing;
- Use high sensitivity waterproof and dustproof microphone head, pickup clear sound;
- Ambient noise cancellation (ANC) technology;
- Waterproof and dustproof level are IP66.

Technical Specifications

Model	DH-HAP320
General	
Scope	5~100 m ²
Sensitivity	-24±3dB
Frequency Response	20Hz~20kHz
Directional Characteristic	Omni-directional
SNR(re 94dBSPL=1Pa@1kHz)	68dB
Dynamic Range	84dB
Max. Sustainable Sound Pressure	110dBSPL (1kHz, THD 1%)
Output Impedance	100Ω (non-equilibrium)
Output Signal Amplitude	2.5Vpp/90dBSPL
Microphone	High-fidelity waterproof microphone
Working Voltage	DC 12V
Working Current	60mA
Working Temperature	-30°C~+70°C (-22°F ~+158°F)
Material	Metal
Color	Silver
Dimension	Φ80mm×23.5mm (Φ3.15"×0.93")
Weight	0.185kg (0.41lb)
Certification	CE/FCC

Interface information

- RCA female connector
- DC Power connector

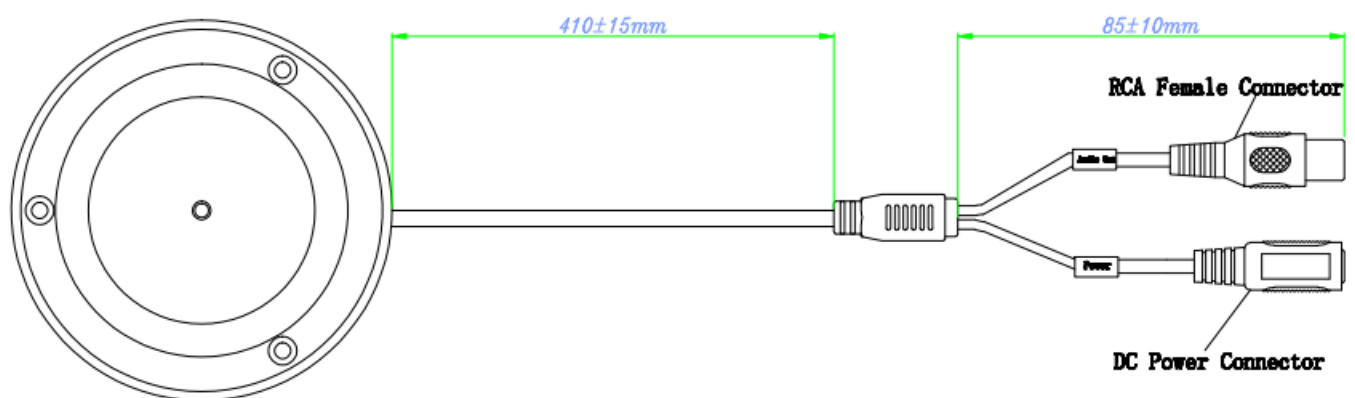

Dimensions (mm/inch)

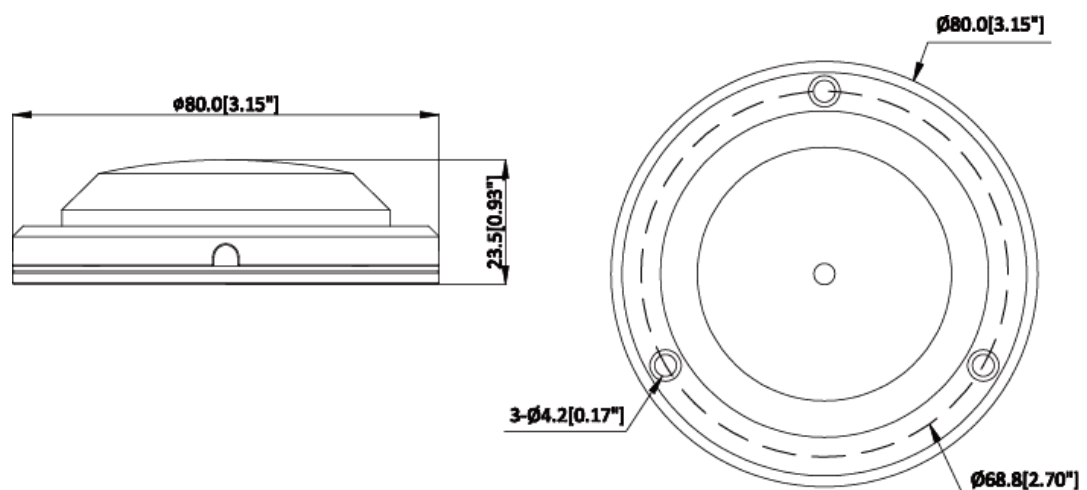

Application scenarios

- It is suitable for the places that need anti-violence such as prisons, house of detention, labor camp and places that needs waterproof such as guards, watch box.

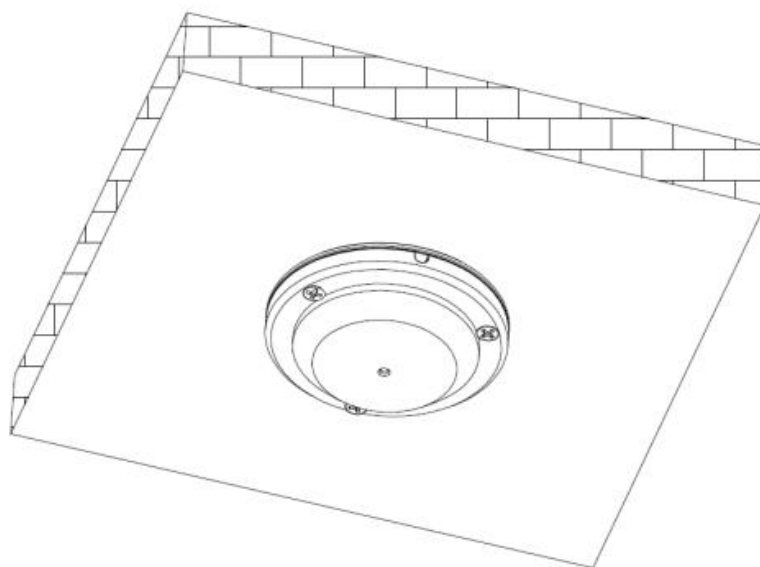

Package Information

- Hi-fidelity pickup *1
- M4 screw & anchor *3
- User manual *1