



inim
ELECTRONICS



Sagittarius

Wireless devices

Instructions



GameOver

Table of contents

Chapter 1	Introduction.....	3
Chapter 2	System architecture.....	4
2.1	Maximum configuration (Wireless section)	4
2.2	Wireless range	4
2.3	Communication mode	4
Chapter 3	System devices	6
Chapter 4	VW2W protocol translator	7
4.1	Connecting the translator to the detection line	7
4.2	Enrolling wireless devices onto the translator	7
4.3	Enrolling locally	8
4.4	LOOP configuration — Translator to Detection Line (Status 0-1)	8
4.5	RF — Enrolling wireless devices on the Loop via Translator (Status 0-2)	9
4.5.1	Enrolling translator (Status 0-2-1)	9
4.5.2	Enrolling/Deleting detector (Status 0-2-2)	10
4.5.3	Enrolling/Deleting input module (Status 0-2-3)	11
4.5.3	Enrolling/Deleting output module (Status 0-2-4)	12
4.5.5	Enrolling/Deleting manual callpoint (Status 0-2-5)	13
4.5.2	Enrolling/Deleting sounder (Status 0-2-6)	13
4.6	Information relating to the translator configuration (Status 0 – 3)	13
4.7	Installation	14
Chapter 5	SG100, SG200, SG350 analogue addressable wireless detectors... 15	
5.1	SG100	16
5.2	SG200	16
5.3	SG350	16
5.4	Test	17
5.5	Tamper	17
5.6	Visual signalling (LED)	17
5.7	Technical specifications	18
5.8	Installation	18
Chapter 6	SGCP100 manual resettable callpoint	20
6.1	Visual signalling (LED)	21
6.2	Technical specifications	21
6.3	Installation	21
Chapter 7	SGMI100 input module.....	22
7.1	Visual signalling (LED)	22
7.2	Technical specifications	22
7.3	Installation	23

Chapter 1

Introduction

The VEGA-SAGITTARIUS integrated wireless system is the result of an accurate analysis of in-depth research into issues relating to difficult applications (for example, notable buildings and places of architectural importance) and the high cost of redecoration work after installation. It is also a truism that wireless systems are unable to effectively replace traditional hard-wired systems, as their reduced-performance (attributable to the deployment of conventional detectors which are incapable of transmitting fault signals) tends to keep maintenance, and consequently running costs, high.

This is why we decided to develop a wire-to-wireless system that provides a means of adapting hard-wired analogue-addressable fire alarm systems to suit the needs of difficult applications.

VEGA is the brand name of a series of analogue-addressable fire-detection devices which interact with control panels via an appropriate communication protocol.

SAGITTARIUS is the name of a series of wireless analogue-addressable fire-detection devices which communicate over a wireless-based gateway through a protocol translator that allows the control panel to manage wireless devices as if they were directly connected to the loop.

System architecture

The wireless section of the fire-alarm system comprises a VW2W interface module that is connected to, and powered by, the loop. The interface communicates with the system it serves through the communication protocol used by the control panel, and receives signals from SAGITTARIUS series devices over the Virtual Wire[®] wireless-based link, that also has the task of ensuring data-transmission quality, device response, etc.

2.1 Maximum configuration (Wireless section)

The VW2W interface module manages 32 addressable points employing the devices listed in Table 1. The control panel regards these as devices with sequential addresses, starting from the address assigned to the translator component (which is directly connected to the loop).

The wireless system comprises a full product line-up of EN54-XX compliant fire detection devices.

These devices have been developed using latest generation wireless communication components resulting in higher efficiencies and lower-power consumption.

The 32 device limit is in accordance with EN54-2 requirements relating to “control and signalling devices”. This standard requires that no more than 32 devices run the risk of being out-of-service at any one time (§12-5-3), due to interruption and/or short-circuit on the detection line.

The wireless transmission between the translator and its devices is as prescribed in the reference standard pr54-24.

2.2 Wireless range

The translator delivers high performance when its devices are at open-area distances of 200m. The range can be extended to by a further 600m by means of a wireless range extender which provides a repeater signal to the main access point.

The system manages up to 6 wireless range extenders on 6 different levels. When all 6 are deployed in conjunction the open-area range can be extended to 3,600m.

2.3 Communication mode

The wireless devices communicate with the translator and wireless range extenders using 868Mhz frequency band with GFSK modulation.

The data transmission system comprises 7 channels. The data transmission channel is selected in accordance with signal quality.

Data transmission is bi-directional with feedback (acknowledge).

In order to avoid interference from other systems in the surrounding area, the system provides several protection features such as: system codes, automatic transmission collision avoidance, cyclic redundancy check (to verify data integrity). The data transmission is crypted too.

The system also automatically manages the transmission power, transmission quality (according to the measured Received Signal strength Indication).

System devices

The following table describes the devices which can be used with the system.

Device	Type	Description
VW2W	Protocol translator	Uses wired communication technology to notify the control panel (VEGA protocol) and wireless communication technology to communicate with its devices
SGWE	Expander	Uses wireless communication technology to communicate with the translator and/or other wireless extenders
SG100	Analogue-addressable optical-smoke detector	Uses wireless communication technology to communicate with the translator and/or other wireless extenders
SG200	Analogue-multicriteria detector	Uses wireless communication technology to communicate with the translator and/or other wireless extenders
SG350	Analogue-heat detector	Uses wireless communication technology to communicate with the translator and/or other wireless extenders
SGCP100	Manual resettable callpoint	Uses wireless communication technology to communicate with the translator and/or other wireless extenders
SGVMI100	Single supervised input module	Uses wireless communication technology to communicate with the translator and/or other wireless extenders
SGVMC100	Single output module	Uses wireless communication technology to communicate with the translator and/or other wireless extenders
SGRS100	Wall-mount sounder	Uses wireless communication technology to communicate with the translator and/or other wireless extenders

Chapter 4

VW2W protocol translator

The VW2W Protocol translator is connected to, and powered by the loop. It communicates with the control panel via VEGA communication protocol.

4.1 Connecting the translator to the detection line

Using terminal 1 (vedi Figura 1), connect the translator to the detection line. Be sure to observe proper polarity.

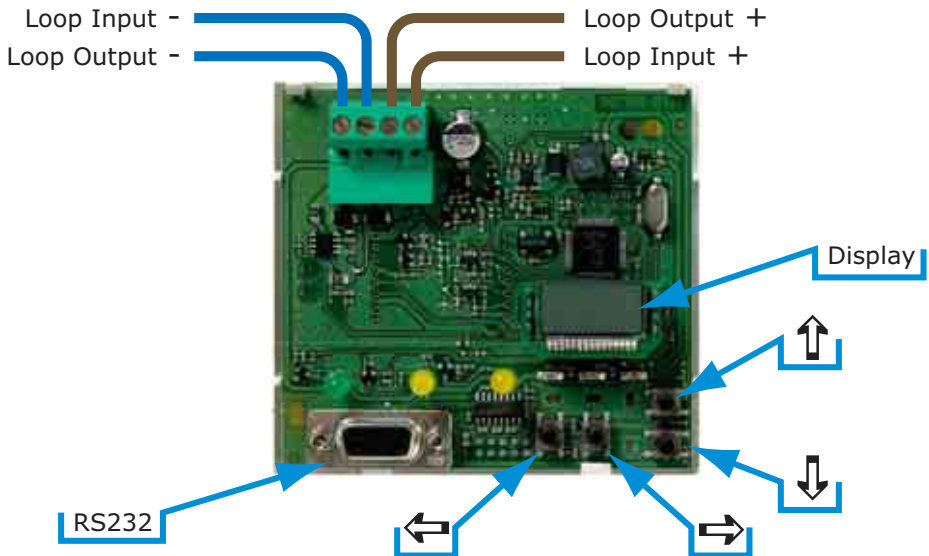

Figure 1 - Board and terminals

4.2 Enrolling wireless devices onto the translator

This operation consists of enrolling all the individual wireless devices onto the translator, and therefore onto the control panel.

Enrolling can be implemented:

- locally, using the keys on the translator
- from a PC via RS232, using the WireEx software application

4.3 Enrolling locally

Connect the translator to the detection line, or to a 24Vdc (15Vdc – 40Vdc) or to the ARGUS 'line driver':

1. On power-up, various symbols appear on the display for approximately 1 second
2. The display then clears (Status 0)

Using the ↓↑ keys, you can scroll the various function statuses:

- **Loop**: allows the configuration of the translator with regard communications between the translator and the detection line.
- **Rf**: allows the configuration of the translator with regard communications between the translator and its wireless devices.
- **Info**: gives information about translator status .

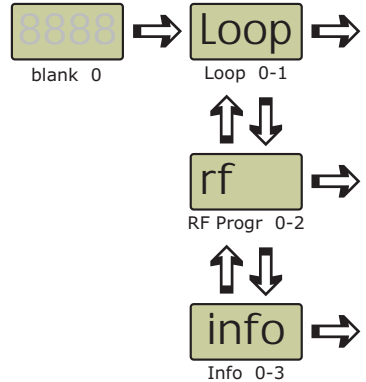

4.4 LOOP configuration — Translator to Detection Line (Status 0-1)

If you select LOOP mode, the system will assign an address to the translator that is connected to the detection line. This address will be the first address of all the wireless devices.

It is not necessary to reserve 32 addresses on the detection line, as only the number of addresses actually required by the translator (for its enrolled wireless devices) will be employed.

1. Status **LOOP**: display will show " Loop " (Status 0-1)
2. Press the ⇒ key: display will show " SA " (Start Address) (Status 0-1-1)
3. Press the ⇒ key: display will show the current address of the translator (Status 0-1-1-1) Using the keys, assign the required address
4. Press the ⇒ key to confirm the selection. The display will show " SA " again and will step back to point 1 (Status 0-1-1), where you can change the address.
5. Press the ⇐ key to exit (Status 0-1)

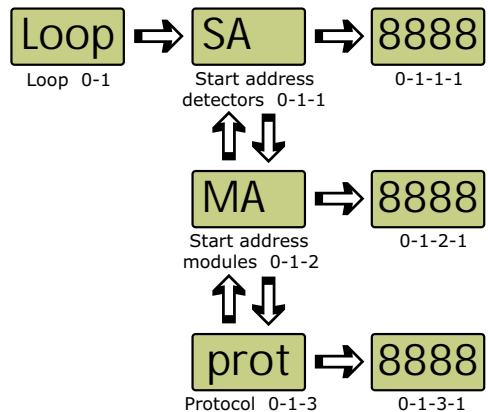

Changing the address of the translator does not entail changing the previously-assigned addresses of the wireless devices, as their new addresses will be assigned automatically (starting from the new address of the translator).

4.5 RF – Enrolling wireless devices on the Loop via Translator (Status 0-2)

If you select RF mode, the system will enroll the wireless section of the translator and the wireless communication device type will be assigned to the translator connected to the detection line.

1. Status **RF**: display will show " rF " (Status 0-2)
2. Press the ⇨ key: display will show " Exp " (Expander) (Status 0-2-1)

Using the ↓↑ keys, scroll the device list and assign the respective device type:

- **Sens**: Enroll smoke, heat and multicriteria detectors (Status 0-2-2)
- **Imod**: Enroll input modules (Status 0-2-3)
- **Omod**: Enroll output modules (Status 0-2-4)
- **CP**: Enroll manual callpoints (Status 0-2-5)
- **Snd**: Enroll sounders (Status 0-2-6)

4.5.1 Enrolling translator (Status 0-2-1)

The enrolment must be implemented before any other operations. This operation involves setting the parameters shown in the following table:

Operation type	Display	Status	Description
System address	Sys	0-2-1-1	Number from 1 to 255. This code ensures that different systems working in the same building do not collide, even when they are operating on the same channel.
Communication mode	Ch	0-2-1-2	Number from 1 to 7. Determines the communication channel the appliance uses to communicate with its connected devices.
Initialisation	Init	0-2-1-3	Assigns the previously set parameters (System code and channel number).
Reset	res	0-2-1-4	Resets all the devices connected to the appliance.
Loads the configuration	LOAd	0-2-1-5	Loads the pre-existing configuration of the system if already downloaded from a PC.

- **System address**: Entails the assignment of an address to the translator. The display will show " Exp " (Status 0-2-1)
 1. Press the ⇨ key: display will show " Sys " (Expander) (Status 0-2-1-1)
 2. Press the ⇨ key: display will show the current address of the translator (Status 0-2-1-1-1)
 3. Using the ↓↑ keys, select the required address.
 4. Press the ⇨ key to confirm the selection. The display will show " Sys " again and will step back to point 1 (Status 0-2-1-1), where you can change the address.

- **Communication mode:**

1. Press the ↓ key: display will show " Ch " (Status 0-2-1-2)
2. Press the ⇒ key: display will show the number of the current communication channel (Status 0-2-1-2-1).
3. Using the ↓↑ keys, select the required communication channel.
4. Press the ⇒ key. The display will show " Ch " again and will step back to point 1 (Status 0-2-1-2), where you can change the channel.
5. Using the ↓↑ keys, select the required communication channel.
6. Press the ⇐ key to go back, step by step, to the start (Status 0-2-1).

- **Initialisation:** Entails the assignment of the previously set parameters (System code and channel number)

1. Press the ↓ key: display will show " Init " (Status 0-2-1-3)
2. Press the ⇒ key: display will show " OOOO ". It indicates that the operation is running. Once the operation has been completed, the display will show " Done ".
3. Press the ⇒ key to go back to the translator addressing phase (Status 0-2-1). The display will show " Exp " .

- **Reset:** this command will reset all the devices that are connected to the translator.

1. Press the ↓ key: display will show " res " (Status 0-2-1-4)
2. Press the ⇒ key: display will show " Done " indicating that the operation has been carried out.
3. Press the ⇒ key to go back to the translator addressing phase (Status 0-2-1): The display will show " Exp " .

- **Load Configuration:** this command will download the configuration settings from the PC.

1. Press the ⇒ key. The display will show " LOAD " (Status 0-2-1-5)
2. Press the ⇒ key. The display will show " Conf " (Stato 0-2-1-5-1). Confirmation of the command will be requested.
3. Press the ⇒ key. The display will show " Done " (Status 0-2-1-5-2) indicating that the operation has been carried out.
4. Press the ⇒ key to go back to the translator addressing phase (Status 0-2-1). The display will show " Exp " .
5. Press the ⇐ key to go back, step by step, to the start (Status 0-2-1).

4.5.2 Enrolling/Deleting detector (Status 0-2-2)

Entails enrolling a detector and its address on the system, or deleting a detector and its address from the system. The method used for the enrolment and deletion applies to all detector types (smoke, heat and multicriteria).

1. The display will show " SENS " (Status 0-2-2).

2. Press the \Rightarrow key. You will access the detector enrolment phase. The display will show " Add " (Status 0-2-2-1).
3. Press the \Rightarrow key. The display will show " LINK " and the radio wave symbol " ' || ' ".

Enrolling a detector

1. Take the detector you intend to enrol on the translator. Check that the secondary battery is present (the battery must be properly located in its housing).
2. Set the switch to the "ON" position. Insert the primary battery; be sure to observe proper polarity. The LED will blink red 4 times and then will go OFF. This indicates that the detector has been identified by the translator.
3. Set the switch to the "1" position. The LED will blink from red to green and then will go OFF. This indicates that the detector has been enrolled on the translator and is communicating properly. The display will show the device address (the system assigns automatically the first available address): " NOXX ".
4. Attach the detector to its base.

Possible Fault signals

If the detector is not properly attached to its base, the display will show the detector number and the Key icon.

If the primary battery is low, the display will show the detector number and " BATT ".

Deleting a detector

1. Press the \downarrow key. You will access the detector deletion phase. The display will show " DEL " (Status 0-2-2-2)
2. Press the \Rightarrow key. The display will show the list of enrolled detectors " OXX " (Status 0-2-2-2-1). Or, if no detectors have been enrolled on the translator, the display will show " none ".
3. Using the $\uparrow\downarrow$ keys, select the address of the detector you wish to delete.
4. Press the \Rightarrow key, the translator will ask for the confirmation. The display will show " Conf ".
5. Press the \Rightarrow key to confirm. The display will show " done ". The detector has been deleted.

4.5.3 Enrolling/Deleting input module (Status 0-2-3)

This operation will allow you to add/remove input modules and their respective addresses on/from the system.

1. The display will show " IMod " (Status 0-2-3)
2. Press the \Rightarrow key. You will access the input module enrolment phase. The display will show " Add " (Status 0-2-3-1).

3. Press the ⇨ key. The display will show " **LINK** " and the radio wave symbol " ' || ' ".

Enrolling an input module

1. Take the modules you intend to enrol on the translator. Check that the secondary battery is present (the battery must be properly located in its housing).
2. Set the switch to the "ON" position. Insert the primary battery; be sure to observe proper polarity. The LED will blink red 4 times and then will go OFF: this indicates that the input module has been identified by the translator.
3. Set the switch to the "1" position. The LED will blink from red to green and then will go OFF. This indicates that the input module has been enrolled on the translator and is communicating properly. The display will show the address assigned to the input module.

Possible Fault signals

If the primary battery is low, the display will show the module number and " **BATT** ".

Deleting an input module

1. Press the ↓ key. You will access the input module deletion phase. The display will show " **DEL** " (Status 0-2-3-2)
2. Press the ⇨ key. The display will show the list of enrolled modules " **OXX** " (Status 0-2-3-2-1). Or, if no modules have been enrolled on the translator, the display will show " **none** ".
3. Using the ↓↑ keys, select the address of the input module you wish to delete.
4. Press the ⇨ key, the translator will ask for the confirmation. The display will show " **Conf** ".
5. Press the ⇨ key to confirm. The display will show " **done** ". The input module has been deleted.

4.5.4 Enrolling/Deleting output module (Status 0-2-4)

This operation will allow you to add/remove output modules and their respective addresses on/from the system. Output modules are not powered by batteries.

1. The display will show " **OMod** " (Status 0-2-4)
2. Press the ⇨ key. You will access the output module enrolment phase. The display will show " **Add** " (Status 0-2-4-1).
3. Press the ⇨ key. The display will show " **LINK** " and the radio wave symbol " ' || ' ".

Enrolling an output module

1. Take the modules you intend to enrol on the translator. Set the switch to the "ON" position.

2. Connect the output module power supply wires to the respective terminals; be sure to observe proper polarity. Power on the module. The LED will blink red 4 times and then will go OFF: this indicates that the output module has been identified by the translator.
3. Set the switch to the "1" position. The LED will blink from red to green and then will go OFF. This indicates that the output module has been enrolled on the translator and is communicating properly. The display will show the address assigned to the output module. The LED will go On green to indicate that the relay is in standby status.

Deleting an output module

1. Press the ↓ key. You will access the output module deletion phase. The display will show " DEL " (Status 0-2-4-2)
2. Press the ⇨ key. The display will show the list of enrolled modules " OXX " (Status 0-2-4-2-1). Or, if no modules have been enrolled on the translator, the display will show " NONE ".
3. Using the ↓↑ keys, select the address of the output module you wish to delete.
4. Press the ⇨ key, the translator will ask for the confirmation. The display will show " Conf ".
5. Press the ⇨ key to confirm. The display will show " done ". The module has been deleted.

4.5.5 Enrolling/Deleting manual callpoint (Status 0-2-5)

This operation will allow you to add/remove manual callpoints and their respective addresses on/from the system.

1. The display will show " CP " (Status 0-2-5)
2. The process of enrolling or deleting a manual callpoint is the same as enrolling or deleting a detector. See paragraph 4.5.2 "Enrolling/Deleting detector (Status 0-2-2)".

4.5.6 Enrolling/Deleting sounder (Status 0-2-6)

This operation will allow you to add/remove sounders and their respective addresses on/from the system.

1. The display will show " Snd " (Status 0-2-6).
2. The process of enrolling or deleting a sounder is the same as enrolling or deleting a detector. See paragraph 4.5.2 "Enrolling/Deleting detector (Status 0-2-2)".

4.6 Information relating to the translator configuration (Status 0 – 3)

During this phase, it will be possible to view information relating to the various devices enrolled on the translator.

1. The display will show " InFO " (Status 0-3)

2. Press the ⇨ key to enter in the LIST phase. The display will show " LIST " (Status 0-3-1)
3. Press the ↓↑ keys to view the type of protocol the translator uses to communicate with the detection line.
4. Press the ⇨ key to view the addresses of the devices connected to the translator. The display will show the first address. Using the ↓↑ keys, scroll the addresses of the devices connected to the translator.
5. Press the ⇨ key to view the type of device at each address.

4.7 Installation

Choose the mounting location that should be dry and far from encumbrances such as large metal objects and sources of electrical noise.

Connect the detection line; be sure to observe proper polarity.

Ensure that the wireless section of the system has been duly configured (i.e. translator and its devices).

Check device communication and signal quality.

When you are sure that the system is operating properly proceed with the installation phase.

Chapter 5

SG100, SG200, SG350 analogue addressable wireless detectors

The SG-XXX series smoke, heat and multi-criteria detectors from the SAGITTARIUS range communicate with the panel via a VW2W wireless translator.

The figure below shows the wireless detector and his base:

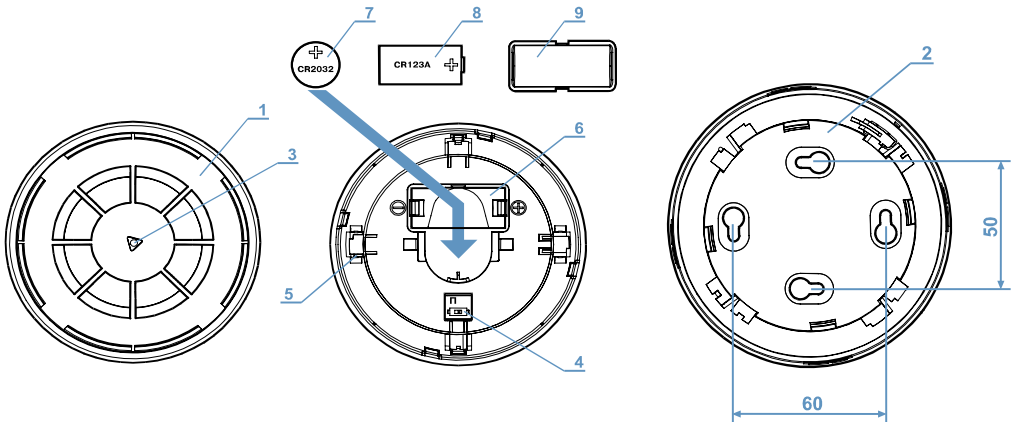

Figure 2 - SG-XXX detector

1	Detector unit	5	Tamper switch
2	Mounting base	6	Primary battery housing
3	Visual signal indicator (the signal light is generated by a bicolour LED with optical fibre light transmission)	7	Secondary battery
4	Device enrolment switch	8	Primary battery
		9	Primary battery cover

5.1 SG100

The SG100 optical smoke detector complies to EN54-7.

The double dust trap ensures high protection against dust contamination and keeps maintenance to a minimum. Variable threshold sensitivity increases the capability of true fire detection and significantly reduces the false alarm rate.

The detector will trigger an alarm if the quantity of smoke in the protected ambient exceeds the alarm threshold.

The status of the detector is indicated on a centrally positioned status LED.

The connection between detector and the control panel to which is reported the status is via wireless protocol.

The periodic Self Test feature ensures full functionality at all times. The occurrence of any of the following fault conditions will be signalled on the LED and reported to the panel:

- optical detection-chamber fault
- contamination
- low battery

5.2 SG200

The SG200 optical smoke and heat detector complies with EN54-5 and EN54-7.

It combines an optical smoke chamber and heat analysis channel in a single detector. An algorithm determines alarm status by analyzing the quantity of smoke inside the chamber and the temperature variation.

The status of the detector is indicated on a centrally positioned status LED.

The connection between detector and the control panel to which is reported the status is via wireless protocol.

The periodic Self Test feature ensures full functionality at all times. The occurrence of any of the following fault conditions will be signalled on the LED and reported to the panel:

- optical detection-chamber fault
- heat analysis channel fault
- contamination
- low battery

5.3 SG350

The SG350 Rate-of-Rise heat detector complies with EN54-7.

Alarm status is triggered by a low heat thermostat which responds to temperature changes that occur within a pre-set period.

The connection between detector and the control panel to which is reported the status is via wireless protocol.

The status of the detector is indicated on a centrally positioned status LED.

The periodic Self Test feature ensures full functionality at all times. The occurrence of any of the following fault conditions will be signalled on the LED and reported to the panel:

- heat analysis channel fault
- low battery

5.4 Test

The periodic Self Test feature ensures full functionality at all times.

Any faults found during the periodic Self Test will be signalled on the detector LED and reported to the panel. The in-built magnet test facility allows easy verification of proper performance of the installed detector system. The magnet test simulates smoke in the detection chamber and therefore tests the electronic circuits of the detector and signal transmission to the control panel.

The detectors can be restored to standby by means of the RESET command from the control panel.

5.5 Tamper

If the detector is removed from its base, it will send a tamper signal to the control panel.

5.6 Visual signalling (LED)

The centrally positioned bicolour status LED (Green/Red) provides full 360° visibility of the detector status, as indicated the following table.

Signals relating to the device status on power up (primary battery inserted) and associated with its translator:

Device status	Green LED	Red LED
Standby mode after power up	Short blink	
Passage to configuration mode after power up		4 short blinks

Signals relating to the battery status:

Device status	Green LED	Red LED
Normal	Off	Off
Primary battery fault		Intermittent blinks 0.1 sec on - 5 sec off
Secondary battery fault	Intermittent blinks 0.1 sec on - 5 sec off	
Primary and secondary battery fault	Intermittent blinks 0.1 sec on - 5 sec off	Intermittent blinks 0.1 sec on - 5 sec off

SGXXX series analogue detectors communicate all status information (smoke level, temperature level and temporal variations in temperature, contamination) to the panel via a VW2W wireless translator.

Detector alarm status is reported to the panel and is signalled locally on a centrally positioned status LED.

The periodic Self Test feature ensures full functionality at all times. The occurrence of any of the following fault conditions (optical detection chamber fault; heat analysis

channel fault; contamination; low battery) will be signalled on the LED and reported to the panel.

5.7 Technical Specifications

Detection devices have the same technical specifications as all other devices on the detection line.

- **Cover:** with regard to cover in the area protected by detection devices, refer to acknowledged national or international application standards and fire codes (for Italy refer to EN9795).
- **Maximum distance between the VW2W and its devices:** about 200m
- **Number of devices per translator:** up to 32 (devices are regarded as having sequential addresses, starting from the address assigned to the translator)
- **Communication frequency:** 868.3 MHz
- **Power supply:** devices are powered by 2 batteries
- **Primary battery:** type CR123A 3V 1.2Ah
- **Secondary battery:** type CR2032A 3V 0.24Ah
- **Battery life:** from 3 to 5 years for the primary battery, 2 months for the secondary battery

5.8 Installation

1. Enrol the device on the translator as previously described (see paragraph 4.5.2 "Enrolling/Deleting detector (Status 0-2-2)").
2. The placement of wireless devices should comply with acknowledged national or international application standards and fire codes (for Italy refer to EN9795).
3. Before proceeding with the installation of the detector, check the wireless signal quality of its placement. Detectors should not be installed in placements with low wireless signal strength.
4. Using the screws, attach the detector base to its placement (vedi Figura 3/A).
5. Lock the detector onto its base (vedi Figura 3/B). Position the detector on its mounting base and rotate it clockwise, applying gentle pressure. The detector will slot into position. Press gently and continue to rotate clockwise a few degrees until the detector is firmly attached to its mounting base (vedi Figura 4/A).
6. Carry out the magnet test: hold a magnet next to the two raised marks on the detector rim (vedi Figura 4/B). The detector should trigger an alarm signal to the control panel and the red LED should blink.



Figure 3 - Positioning

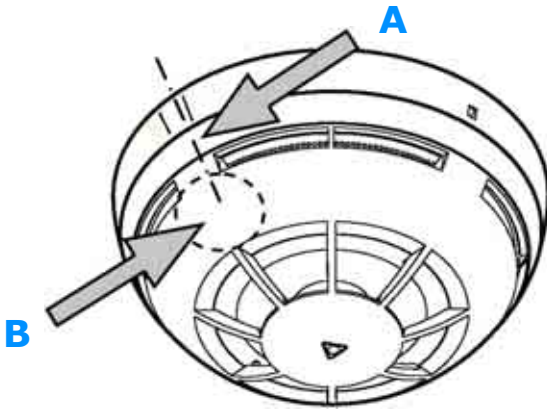

Figure 4 - Alignment

SGCP100 manual resettable callpoint

The resettable callpoint is housed in a plastic enclosure with a plexiglass operating element. The easy turn-key reset method makes the unit ready for immediate re-use after reset operations.

On activation the LED (controlled by the control panel) goes On (red) and a yellow-striped flag appears. Activation of the unit simulates a "break-glass" scenario (particularly useful in places with frequent false alarms such as schools, shopping malls, etc.) and triggers an alarm.

Removal of the device from its placement will generate a fault signal to the panel.

The callpoint comprises:

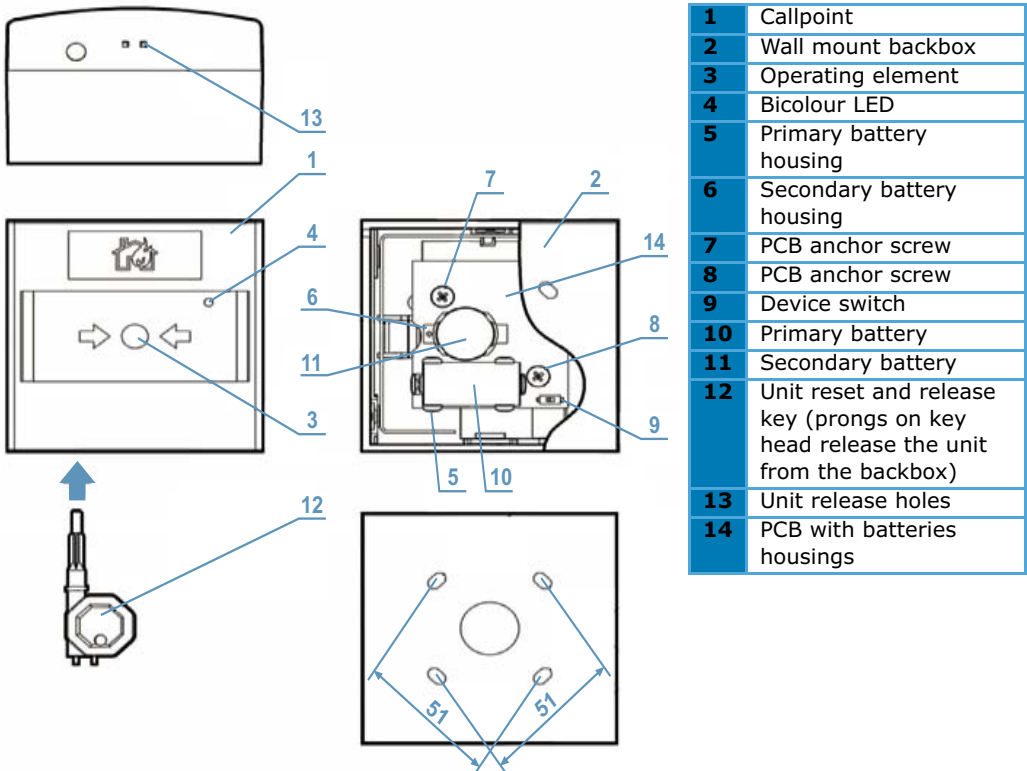

Figure 5 - Manual resettable callpoint

6.1 Visual signalling (LED)

The centrally positioned bicolour LED (red/green) provides the following visual indication of the device and battery status:

Device status	Green LED	Red LED
Normal	Off	Off
Primary battery down		Intermittent blinks 0.1 sec on - 5 sec off
Secondary battery down	Intermittent blinks 0.1 sec on - 5 sec off	
Primary and secondary battery down	Intermittent blinks 0.1 sec on - 5 sec off	Intermittent blinks 0.1 sec on - 5 sec off
Fire alarm		Intermittent blinks 0.1 sec on - 0.1 sec off

6.2 Technical Specifications

Detection devices have the same technical specifications as all other devices on the detection line.

- **Cover:** with regard to cover in the area protected by detection devices, refer to acknowledged national or international application standards and fire codes (for Italy refer to EN9795).
- **Maximum distance between the VW2W and its devices:** about 200m
- **Number of devices per translator:** up to 32 (devices are regarded as having sequential addresses, starting from the address assigned to the translator)
- **Communication frequency:** 868.3 MHz
- **Power supply:** devices are powered by 2 batteries
- **Primary battery:** type CR123A 3V 1.2Ah
- **Secondary battery:** type CR2032A 3V 0.24Ah
- **Battery life:** from 3 to 5 years for the primary battery, 2 months for the secondary battery

6.3 Installation

1. Enrol the callpoint on the translator as previously described (see paragraph 4.5.5 "Enrolling/Deleting manual callpoint (Status 0-2-5)").
2. The placement of wireless devices should comply with acknowledged national or international application standards and fire codes (for Italy refer to EN9795).
3. Before proceeding with the installation, check the wireless signal quality of its placement. Callpoint should not be installed in placements with low wireless signal strength.
4. Using the screws, attach the backbox to its placement.
5. Using light pressure, attach the callpoint unit to the backbox.
6. Carry out a functionality test by pressing the plexiglass operating element (alarm button). The callpoint should trigger an alarm signal to the control panel and the red LED should blink. The callpoint can be reset after the test by inserting the key into the keyhole and turning it clockwise. After this, it is possible to reset the system from the control panel.

SGMI100 input module

The SGMI100 supervised alarm input module monitors the status of external devices (gas detectors, etc.) for interface with the fire detection systems.

The supervised input is configured with an End-Of-Line resistor for line supervision.

7.1 Visual signalling (LED)

The bicolour LED (red/green) provides the following visual indication of the alarm or fault status.

Signals relating to the device status on power up (primary battery inserted) and associated with its translator:

Device status	Green LED	Red LED
Standby mode after power up	Short blink	
Passage to configuration mode after power up		4 short blinks

Signals relating to the battery status:

Device status	Green LED	Red LED
Normal	Off	Off
Primary battery down		Intermittent blinks 0.1 sec on - 5 sec off
Secondary battery down	Intermittent blinks 0.1 sec on - 5 sec off	
Primary and secondary battery down	Intermittent blinks 0.1 sec on - 5 sec off	Intermittent blinks 0.1 sec on - 5 sec off
Fault		Singular 0.1sec blink
Acknowledgement of alarm signal to panel		Intermittent blinks 0.1 sec on - 0.1 sec off

7.2 Technical Specifications

- R_{eol} (line control resistance): 5.7 k Ω
- R_{al} (alarm resistance): 2.2 k Ω
- **Supervision pulsed voltage:** 2.5V
- **Supervision current consumption:** 0.4mA

- **Cover:** with regard to cover in the area protected by detection devices, refer to acknowledged national or international application standards and fire codes (for Italy refer to EN9795).
- **Maximum distance between the VW2W and its devices:** about 200m
- **Number of devices per translator:** up to 32 (devices are regarded as having sequential addresses, starting from the address assigned to the translator)
- **Communication frequency:** 868.3 MHz
- **Power supply:** devices are powered by 2 batteries
- **Primary battery:** type CR123A 3V 1.2Ah
- **Secondary battery:** type CR2032A 3V 0.24Ah
- **Battery life:** from 3 to 5 years for the primary battery, 2 months for the secondary battery

7.3 Installation

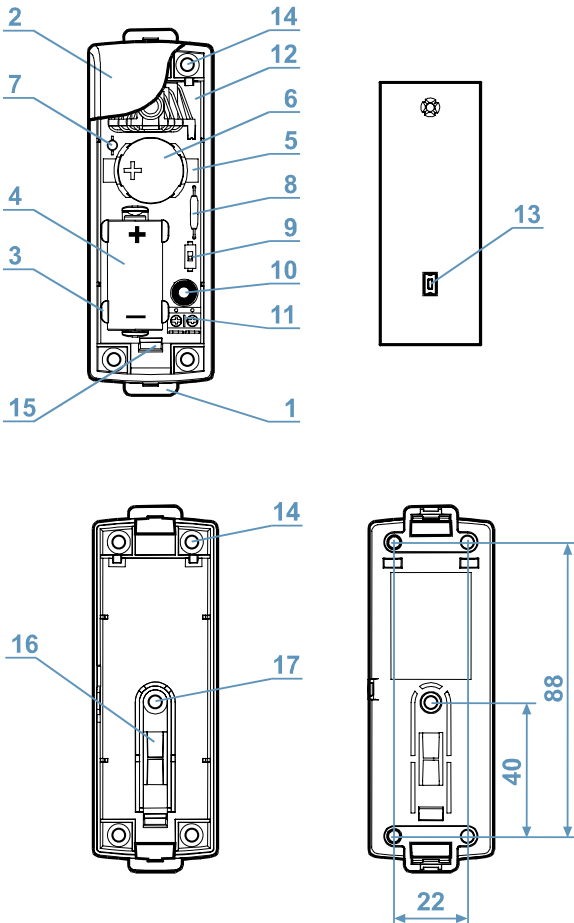

1	Backbox
2	Cover
3	Primary battery housing
4	Primary battery
5	Secondary battery housing
6	Secondary battery
7	Bicolour LED
8	Reed relay
9	Device switch
10	Open-device tamper spring
11	Input terminals
12	PCB
13	Disengagement-tamper switch
14	Anchor screw holes
15	PCB housing
16	Disengagement-tamper spring
17	Disengagement-tamper screw holes

Figure 6 - Single supervised input module

1. Enrol the input module on the translator as previously described (see paragraph 4.5.3 "Enrolling/Deleting input module (Status 0-2-3)").
2. Choose a suitable placement.
3. Check the wireless signal quality of the chosen placement.
4. Using the screws (14), secure the backbox (1) to the wall. To allow the device to detect disengagement tamper (forced removal from its location), remove the PCB.
5. Carry out a functionality test. Activate the alarm. The device should trigger an alarm signal to the control panel and the red LED should blink.

Opening or short circuit on the line that connects the command device (vedi Figura 7) will send a fault signal and relative message to the control panel and the red LED located on the module will blink.

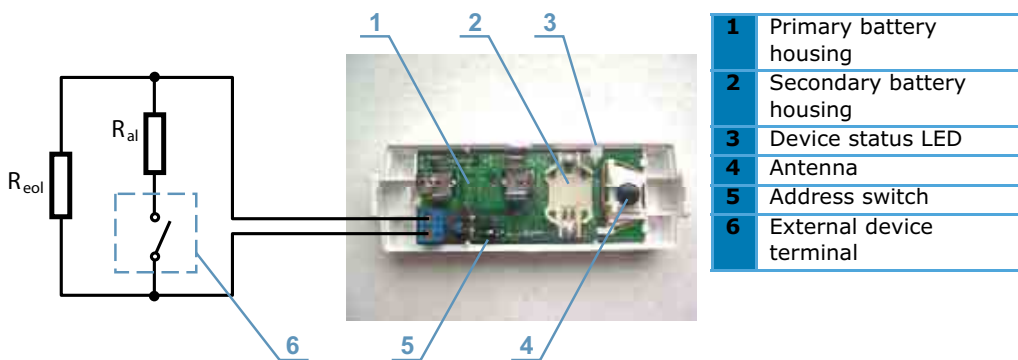

Figure 7 - Terminals

INIM Electronics s.r.l.

via Fosso Antico, Centobuchi
63033, Monteprandone, (AP)
Italy

Tel. +39 0735 70 50 07

Fax + 39 0735 70 49 12

www.inim.biz

info@inim.biz

INIM Electronics reserves the right to change the technical specifications of this product without prior notice.