

HE42XD2/HE42XD2G

TDN 1080p IR Ball Camera



HE42XD2



HE42XD2G

HD

OPERATIONAL	
VIDEO STANDARD	NTSC/PAL
SCANNING SYSTEM	Progressive scan
IMAGE SENSOR	1/2.8" 2.1 MP CMOS
EFFECTIVE PIXELS (H × V)	1937 × 1097
MINIMUM ILLUMINATION	0.005 lux colour @ F1.3, 30IRE, 0 lux B/W with IR LEDs on @ F1.3
S/N RATIO	> 65 dB
ELECTRONIC SHUTTER SPEED	NTSC: 1/3 – 1/100,000 s PAL: 1/4 – 1/100,000 s
RESOLUTION	1080p (1920 × 1080)
FRAME RATE	25/30 fps @ 1080p 25/30 fps @ 720p
VIDEO OUTPUT	1-channel BNC CVI/TVI/AHD/CVBS video output
IR DISTANCE	Up to 150 ft. (50 m), depending on scene reflectance
NUMBER OF IR LEDES	2 High Power IR LEDs
SMART IR	Auto/Manual
DAY/NIGHT	Auto (ICR)/Manual
BACKLIGHT COMPENSATION	BLC/HLC/WDR
WHITE BALANCE	Auto/Manual
GAIN CONTROL	AGC
WIDE DYNAMIC RANGE	120 dB
NOISE REDUCTION	2DNR/3DNR
PRIVACY MASKING	Up to 4 configurable areas
LENS	2.7 – 13.5 mm, MFZ lens, F1.3
HORIZONTAL ANGLE OF VIEW	102° ~ 29°
AUDIO	N/A

ELECTRICAL	
POWER SUPPLY	12 VDC ±25%
POWER CONSUMPTION	7.2 W max. (IR LEDs on)
MECHANICAL	
DIMENSIONS	Ø135.0 mm × 102.6 mm (Ø5.31" × 4.04")
PRODUCT WEIGHT	0.59 kg (1.30 lb.)
PACKAGE WEIGHT	0.74 kg (1.63 lb.)
CONSTRUCTION	Die-cast aluminum housing with powder coat
CONSTRUCTION COLOUR	HE42XD2: RAL 9003 (White) HE42XD2G: RAL 7022 (Gray)
ENVIRONMENTAL	
OPERATING TEMPERATURE	-40°C to 60°C (-40°F to 140°F)
COLD START	Startup should be done at above -40°C (-40°F)
STORAGE TEMPERATURE	-40°C to 60°C (-40°F to 140°F)
RELATIVE HUMIDITY	Less than 90%, non-condensing
INGRESS PROTECTION	IP66
REGULATORY	
EMISSIONS	EN55032, ANSI C63.4-2014
IMMUNITY	EN50130-4
SAFETY	EU: EN60950-1
ROHS	EN50581

RECOMMENDED ACCESSORIES

SYSTEM COMPATIBILITY	
HRHQ104* HQA DVRS	4-channel, 720p@120/100 fps, 1080p@60/50 fps, 1 SATA, alarm I/O
HRHQ108* HQA DVRS	8-channel, 720p@240/200 fps, 1080p@120/100 fps, 2 SATA, alarm I/O
HRHQ116* HQA DVRS	16-channel, 720p@480/400 fps, 1080p@240/200 fps, 2 SATA, alarm I/O

HOUSING AND MOUNTS		
HQA-WK		Wall Mount Adapter
HQA-PM2		Pole Mount Adapter

* Pre-installed storage (TB).

TDN 1080p IR Ball Cameras

ORDERING

HE42XD2	TDN 1080p IR Ball Camera, 1/2.8" 2.1 MP CMOS, 2.7-13.5 mm MFZ Lens, 2 High Power IR LEDs, 12 VDC, IP66, Off-White
HE42XD2G	TDN 1080p IR Ball Camera, 1/2.8" 2.1 MP CMOS, 2.7-13.5 mm MFZ Lens, 2 High Power IR LEDs, 12 VDC, IP66, Gray

DIMENSIONS

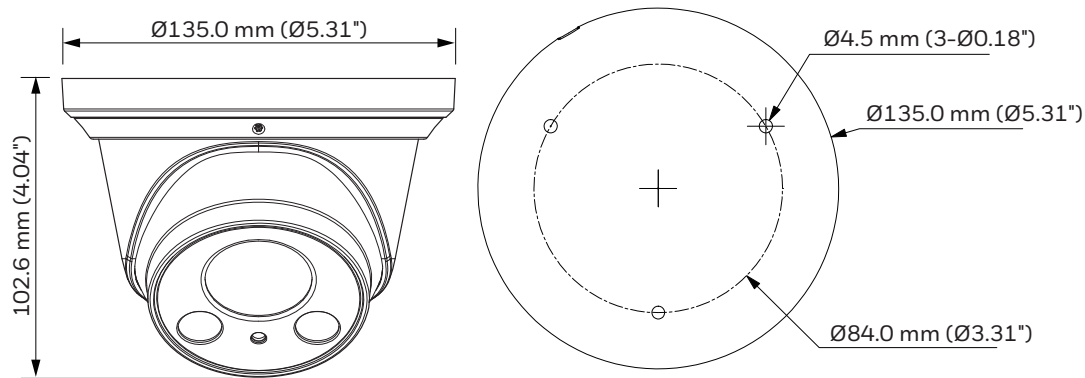

For more information

www.honeywell.com/security

Honeywell Security and Fire

Aston Fields Road
Whitehouse Industrial Estate
Runcorn, Cheshire, WA7 3DL
United Kingdom
Tel: +44 (0)8448 000 235
www.honeywell.com

Honeywell Security Office -

Emaar Business Park, Sheikh Zayed Road
Building No. 2, 2nd floor, 201
Post Office Box 232362
Dubai, United Arab Emirates
Tel: +971 44541704
www.honeywell.com

Honeywell reserves the right, without notification, to make changes in product design or specifications.

HSFV-HE42XD2D-01-UK(1117)DS-E
November 2017
© 2017 Honeywell International Inc.

Honeywell