











FPO-5000-PSB-CH











F.01U.078.860



BOSCH

cs	Instalační manuál Držák napájecích zdrojů	it	Manuale di installazione Staffa alimentazione
da	Installationsmanual Strømforsyningsbeslag	nl	Installatiehandleiding Beugel voedingseenheid
de	Installationsanleitung Netzteilhalterung	no	Monteringsinstruksjoner Strømforsyningsbrakett
el	Οδηγίες συναρμολόγησης Κονσόλα ηλεκτρικής τροφοδοσίας	pl	Instrukcja instalacji Wspornik zasilacza
en	Installation Guide Power supply bracket	pt	Manual de Instalação Suporte de fonte de alimentação
es	Manual de Instalación Abrazadera de fuente de alimentación	ro	Manual de Instalara Suport sursă de alimentare
fi	Asennusohjeet Virtalähdepidike	ru	Инструкция по установке Кронштейн источника питания
fr	Manuel d'installation Console d'alimentation électrique	sl	Priročnik za montažo Okvir za dovod moči
hr	Priručnik za instaliranje Nosač napajanja	sv	Installation manual Elförsörjningskonsol
hu	Telepítési kézikönyv Tápegységkonzol	tr	Kurulum kılavuzu Güç kaynağı ayağı

cs	 NEBEZPEČÍ	NEBEZPEČÍ ÚRAZU ELEKTRICKÝM PROUDEM! Nebezpečí ohrožení života při dotyku vodivých dílů. Před připojováním zařízení odpojte od zdroje napětí!
da	 FARE	FARE FOR ELEKTRISK STØD! Livsfare ved berøring af strømførende dele. Slå strømmen fra, før der tilsluttes udstyr!
de	 GEFAHR	GEFAHR EINES STROMSCHLAGS! Lebensgefahr bei Berührung stromführender Teile. Vor Installationsarbeiten die Stromzufuhr abschalten!
el	 ΚΙΝΔΥΝΟΣ	ΚΙΝΔΥΝΟΣ ΗΛΕΚΤΡΟΠΛΗΞΙΑΣ! Θανάσιμος κίνδυνος κατά την επαφή με τα ρευματοφόρα εξαρτήματα. Αποσυνδέστε την ισχύ πριν συνδέσετε το εξάρτημα!
en	 DANGER	RISK OF ELECTRIC SHOCK ! Danger of life with contact of live parts and wires. Disconnect power before connecting equipment!
es	 PELIGRO	¡RIESGO DE UNA DESCARGAS ELÉCTRICA! Peligro de muerte al entrar en contacto con piezas que conduzcan corriente. Desconectar la alimentación antes de conectar el equipo!
fi	 VAARA	SÄHKÖISKUN VAARA! Sähköä johtavien osien koskettaminen voi aiheuttaa hengenvaaran. Katkaise virta ennen laitteiden liittämistä!
fr	 DANGER	RISQUE DE CHOC ÉLECTRIQUE ! Danger de mort en cas de contact avec les éléments sous tension. Débrancher l'alimentation avant de connecter l'équipement.
hr	 OPASNOST	OPASNOST OD STRUJNOG UDARA! Opasnost po život pri kontaktu s delovima pod naponom. Isključite napajanje prije priključivanja opreme!
hu	 NEBEZPEČÍ	ÁRAMÜTÉSVESZÉLY! Az áramot vezető alkatrészek érintése életveszélyes. Valamely felszerelés csatlakoztatása előtt áramtalanítsa!

it	 PERICOLO	PERICOLO DI SCOSSA ELETTRICA! Pericolo di morte attraverso il contatto con elementi conduttori di elettricità. Interrompere l'alimentazione prima di collegare le attrezzature!
nl	 GEVAAR	GEVAAR VAN EEN STROOMSTOOT! Het aanraken van stroomgeleidende onderdelen is levensgevaarlijk. Sluit de voeding af voordat u apparatuur aansluit!
no	 FARE	FARE FOR ELEKTRISK STØT! Berøring av de strømførende delene kan medføre livsfare. Koble fra strømmen før du kobler til utstyret!
pl	 NIEBEZPIECZEŃSTWO	RYZIKO PORAŻENIA PRĄDEM ELEKTRYCZNYM! Śmiertelne niebezpieczeństwo przy dotknięciu części pod napięciem. Przed dołączeniem urządzeń należy odłączyć zasilanie!
pt	 PERIGO	PERIGO DE ELECTROCUSSÃO! Perigo de vida ao tocar nas peças condutoras de corrente. Desligue a alimentação antes de ligar o equipamento!
ro	 PERICOL	PERICOL DE ELECTROCUTARE! Pericol de moarte la atingerea părților purtătoare de curent! Întrerupeți alimentarea înainte de a conecta echipamentul!
ru	 ОПАСНОСТ	ОПАСНОСТЬ ПОРАЖЕНИЯ ЭЛЕКТРИЧЕСКИМ ТОКОМ! опасность для жизни при соприкосновении с токопроводящими деталями. Перед присоединением оборудования отсоединить питание!
sl	 NEVARNOST	NEVARNOST ELEKTRIČNEGA ŠOKA! Dotik delov pod električno napetostjo je smrtno nevaren. Pred priključitvijo opreme izklopite napajanje!
sv	 RISK	RISK FÖR STRÖMÖVERSLAG! Livsfara vid beröring av strömförande delar. Koppla bort strømmen innan du ansluter utrustning!
tr	 TEHLÝKE	ELEKTRİK ÇARPMASI TEHLİKESİ! Elektrik iletken parçalar dokunulması durumunda hayati tehlike. Donanımı bağlamadan önce güç bağlantısını kesin!

HCP 0006 A HBC 0010 A HBE 0012 A

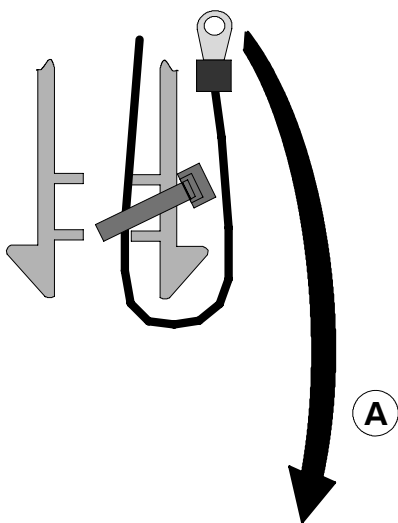
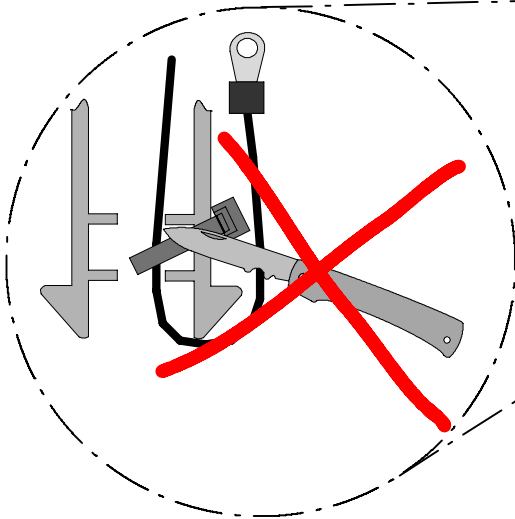
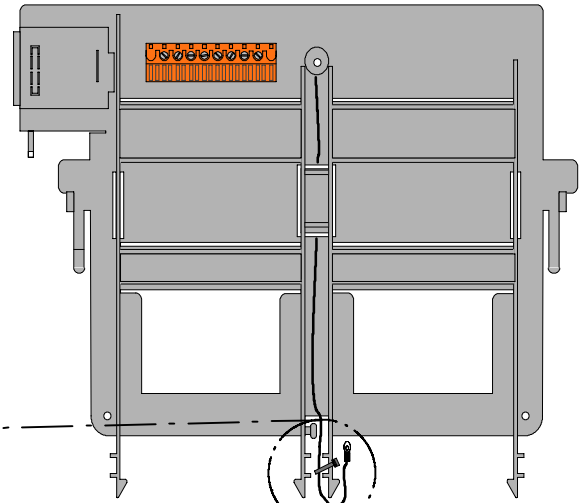
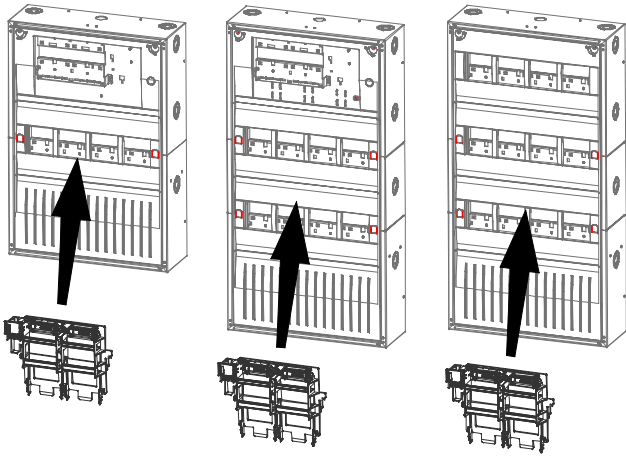

A

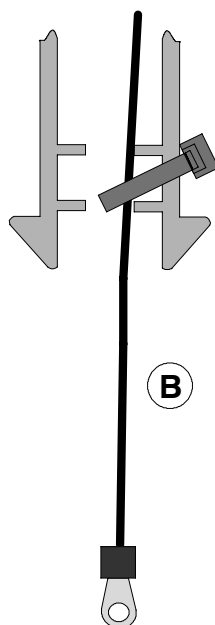

B

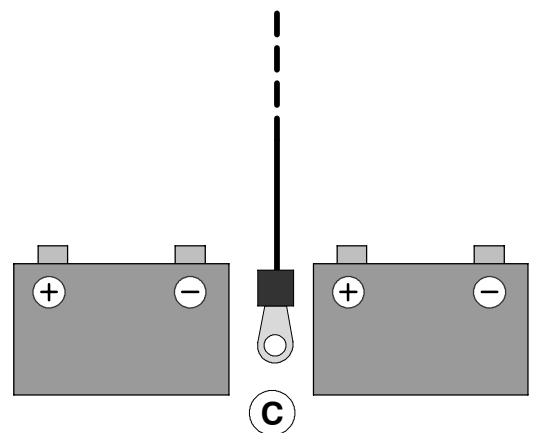

C

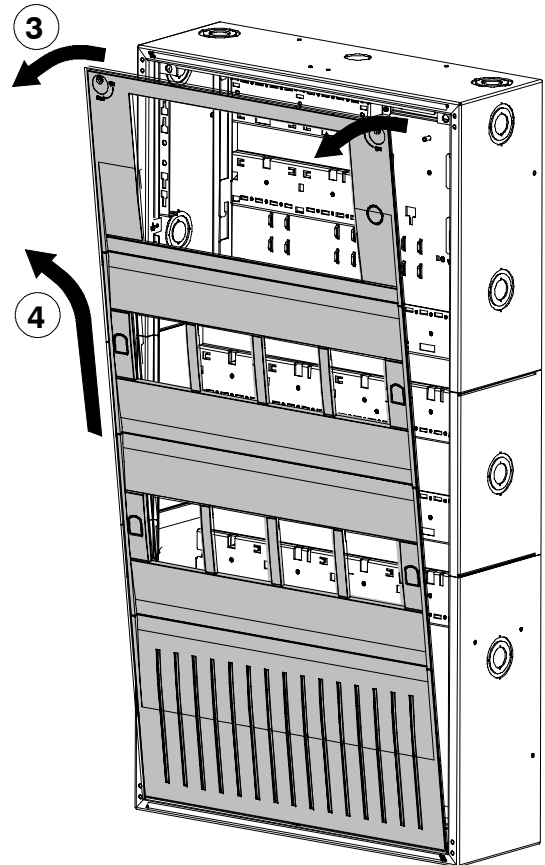
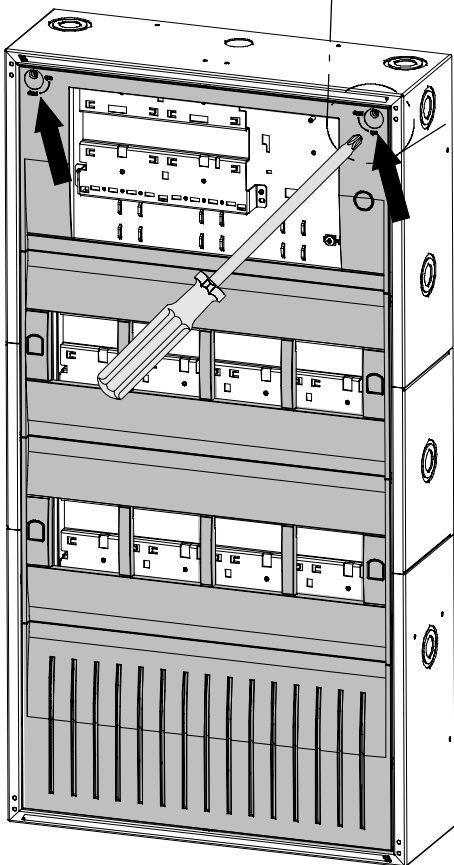
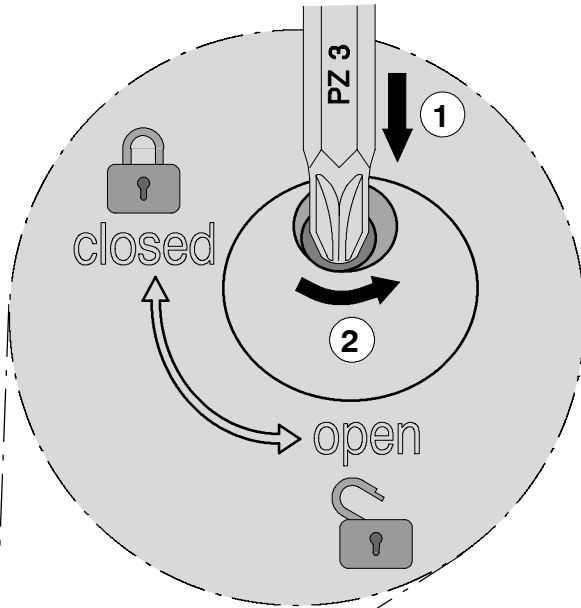
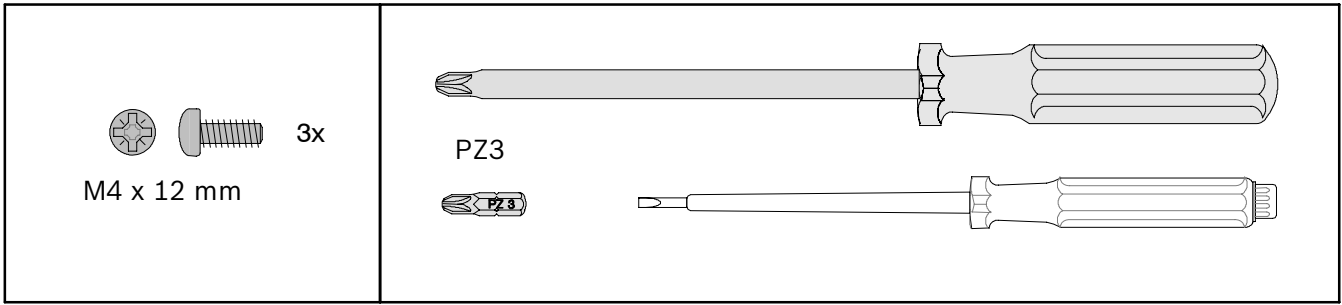

5

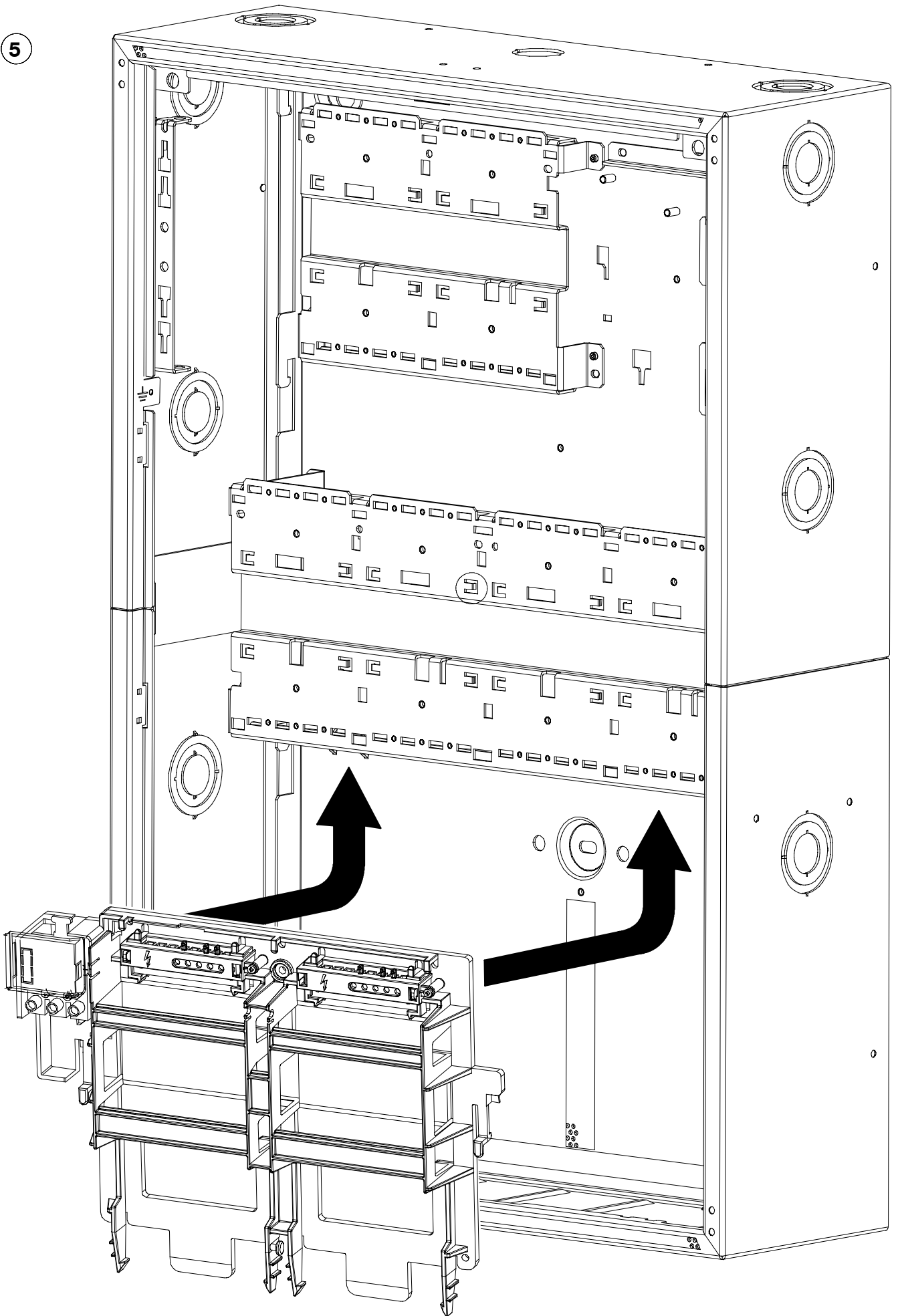

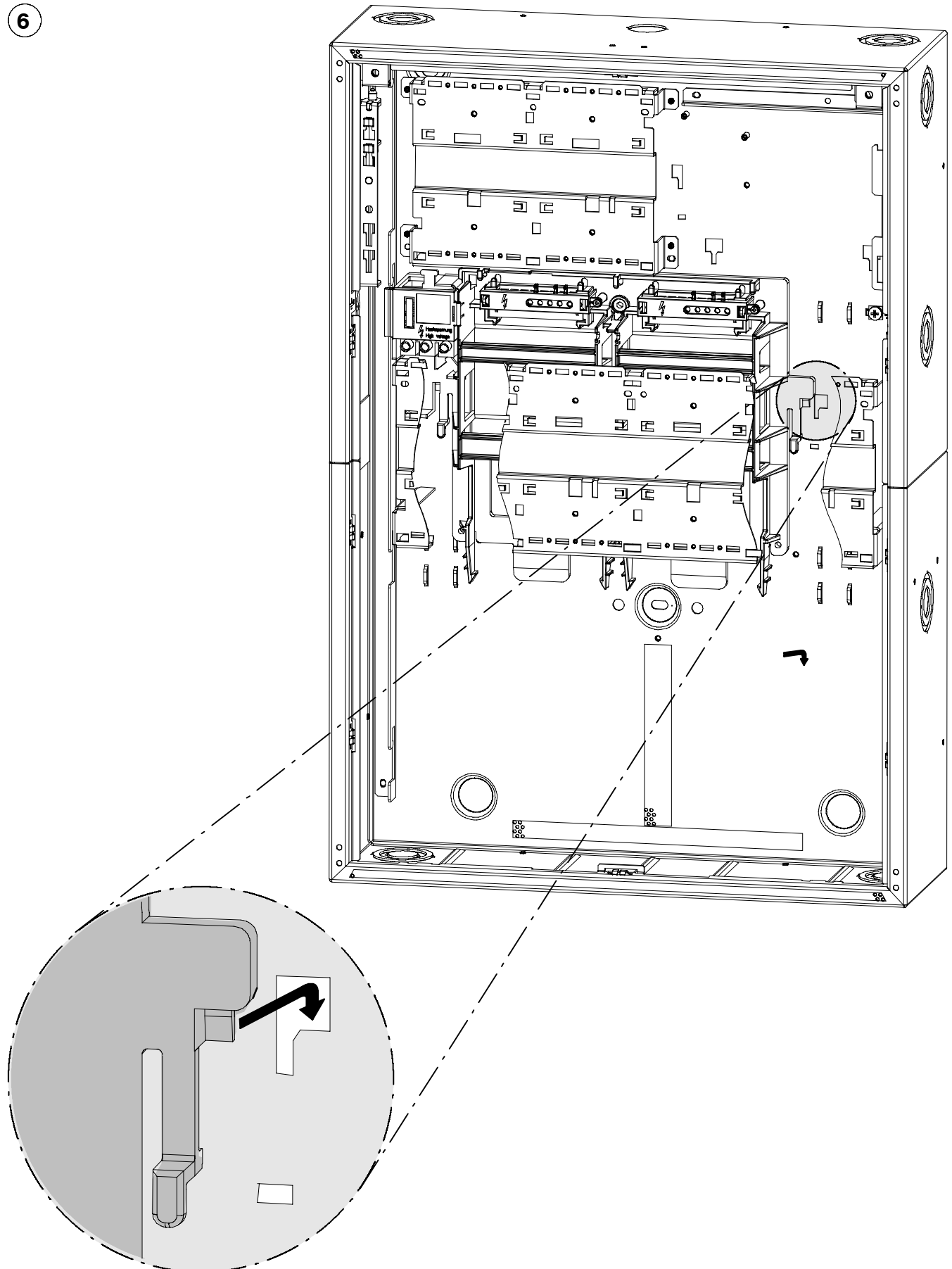

7

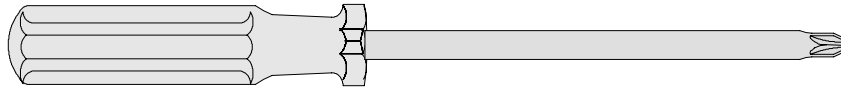

3x

M4 x 12 mm

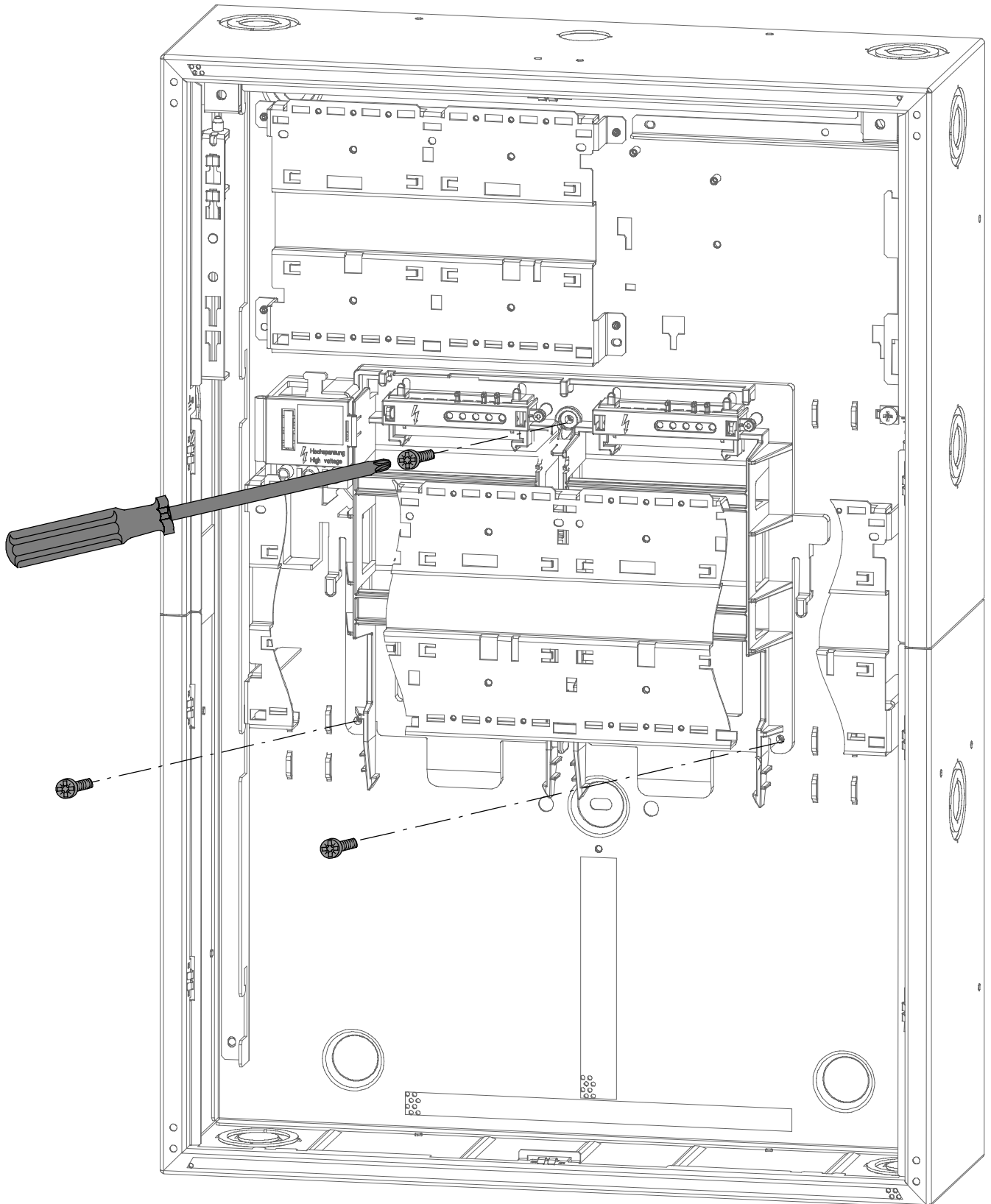

8

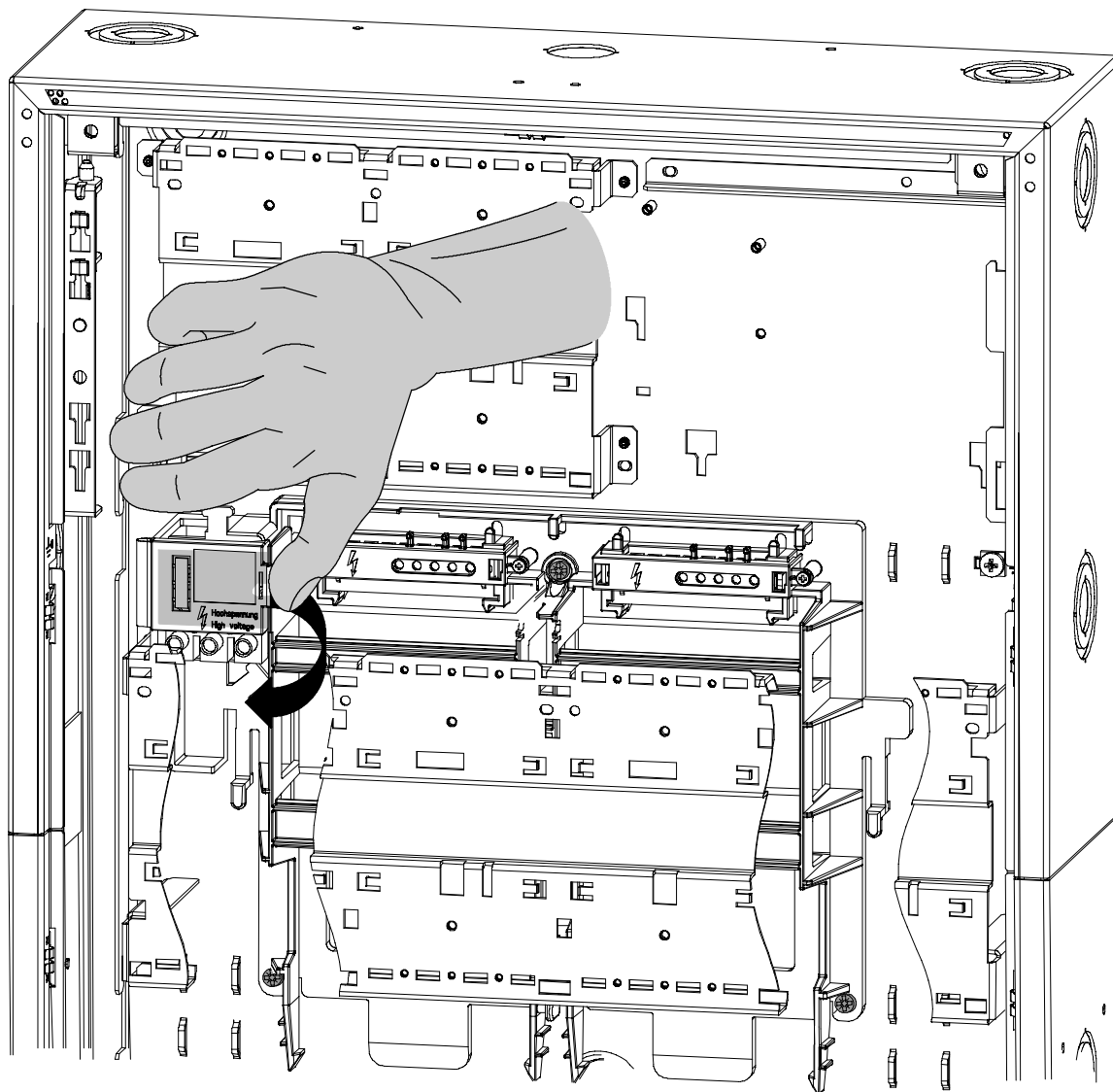

9

T 10 A / 250 V



100 - 240 V AC
50 - 60 Hz

L1 | G | N

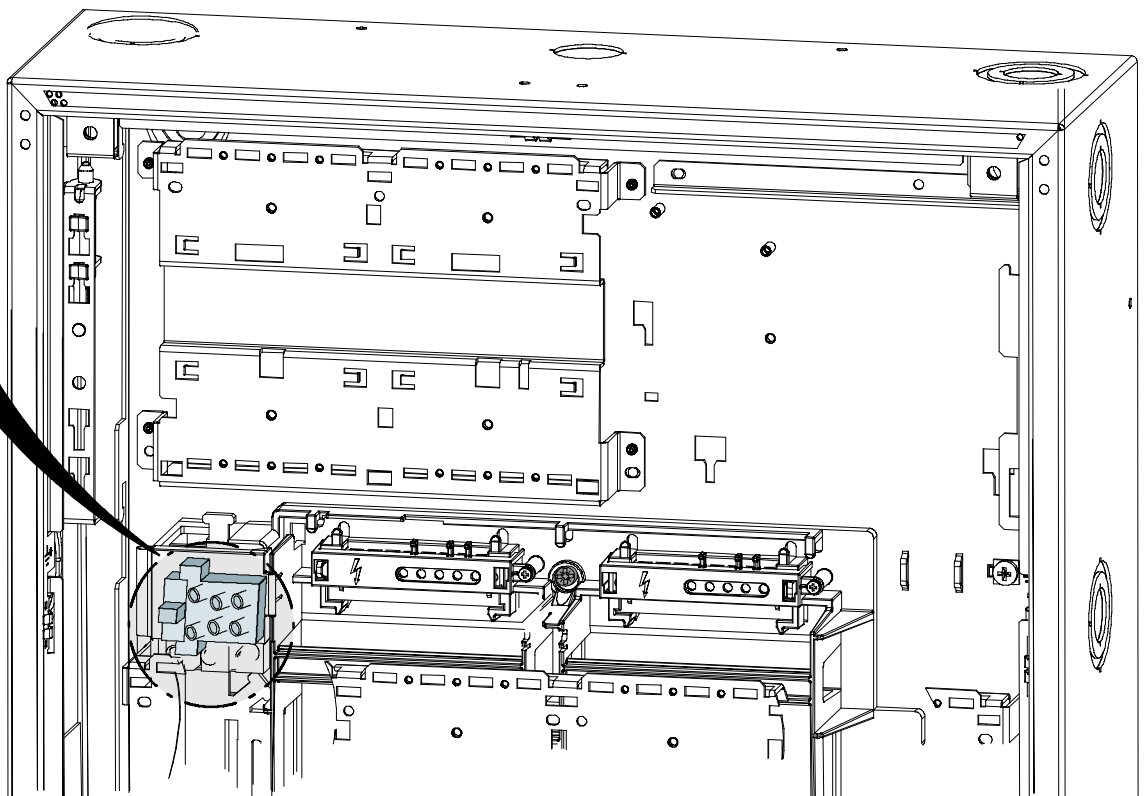
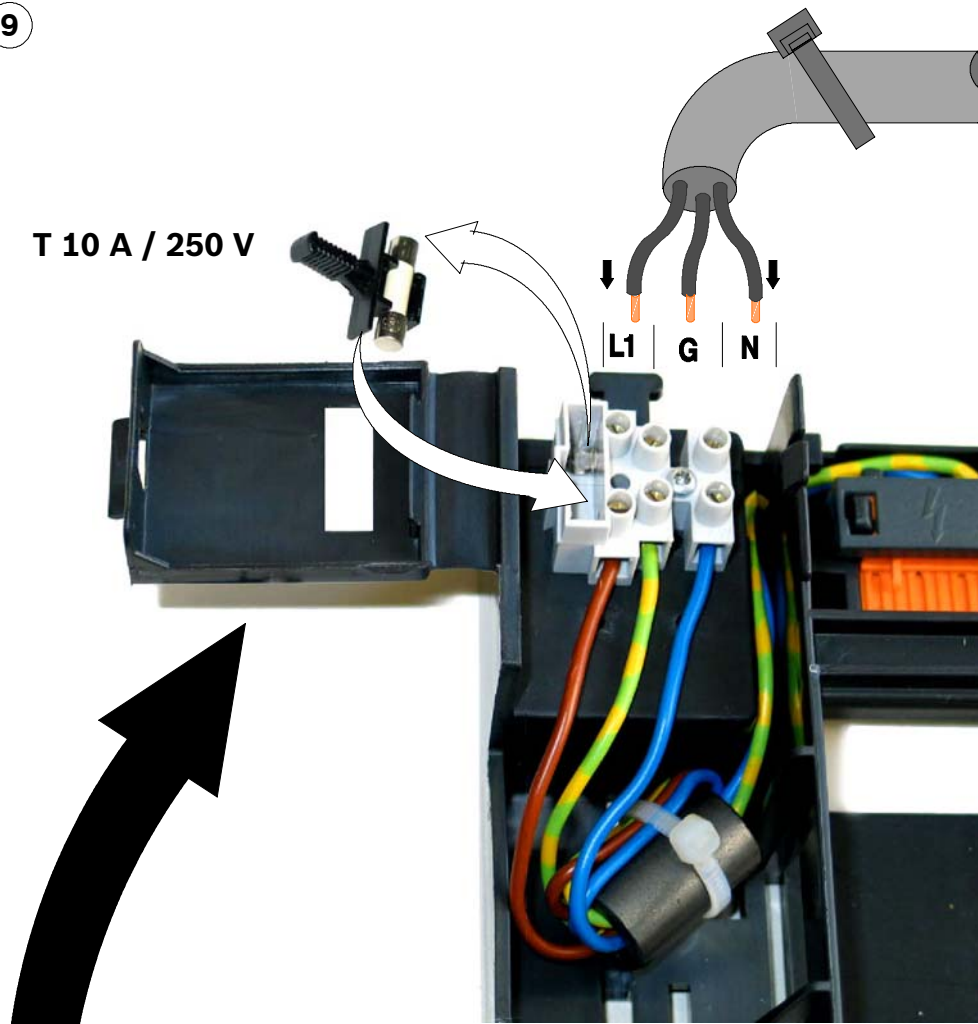

Bosch Sicherheitssysteme GmbH

Robert-Koch-Strasse 100

DS-85521 Ottobrunn

Germany

Telefon +49 (0)89 6290-0

Telefax +49 (0)89 6290-1020

www.boschsecurity.com

©Bosch Sicherheitssysteme GmbH, 2009